

New

Wireless Sensing Receiver • Repeater



System Configuration Products

Required for Wireless Sensing

Wireless Sensing Receiver • Repeater

Additional Line-up Model YWA0500

Receiver Model YWA
Repeater Model YWB



System Configuration Products Required for Wireless Sensing

Model No. Indication

Receiver

YWA 100 0 - B03 - E

1 2 3 4



1 Classification

- 050** : Entry Model (Number of Receivable Connections : Max. 4)
- 100** : Standard Model (Number of Receivable Connections : Max. 8)

3 Available Country : Frequency

- B01** : Japan
 - B02** : Europe, China
 - B03** : United States
- ※ There are restrictions on countries where the product can be used according to radio regulations. Please follow the regulatory requirements of each country.

2 Design No.

0 : Revision Number

4 Monitor Display Language

- E** : English
- J** : Japanese
- C** : Chinese (Simplified)

Repeater

YWB 100 0 - B03

1 2 3

1 Classification

- 100** : Standard Model

3 Available Country : Frequency

- B01** : Japan
- B02** : Europe, China
- B03** : United States

2 Design No.

0 : Revision Number

※ There are restrictions on countries where the product can be used according to radio regulations. Please follow the regulatory requirements of each country.



System Configuration Diagram

Customer Preparation (Machine Side)

Command Signal from Machine Side
Signal to control the receiver.
Reset Signal for Clamping State

Power DC24V

Clamping State Signal to Machine Side
Signal to identify the clamp operation.
Unclamp Signal of 1st Clamp
Unclamp Signal of 2nd Clamp
⋮
Unclamp Signal of 8th Clamp
* In case of YWA0500 : Up to 4th Clamp

Power DC24V

Operating Hydraulic or Air Pressure
Double Acting : 2 ports
Single Acting : 1 port

For Clamp Operation
For Unclamp Operation

Position : Outside Machine

Receiver Clamp · Linear Cylinder
Max. Number of Connections :
YWA0500 : 4, YWA1000 : 8



Transmit an unclamp/stroke-end signal by radio wave

Position : Near Fixture
Inside the Processing Machine

Repeater Improves radio wave strength and reliability.



Transmit an unclamp/stroke-end signal by radio wave

Position : Near Fixture

Wireless Sensing Clamp/ Linear Cylinder

※ Max. distance between the clamp and the receiver : 5m
(when there is no obstruction.)



● Specifications : Receiver model YWA 0-B-

This receiver receives unclamp and stroke-end confirmation signals from wireless sensing clamps, linear cylinders (model LHM / LKM / LLM / LGM / LJM / WHP / WCP), and repeater (model YWB) and displays them on a monitor and outputs them to an external device. Clamping state, operating time, and radio wave condition can be checked on the monitor. The output contact can be turned off and the operating time can be reset by switching the clamping state reset.



Model No.	YWA0500-B <input type="checkbox"/> - <input type="checkbox"/>	YWA1000-B <input type="checkbox"/> - <input type="checkbox"/>
Receiving Frequency	3 When selecting B01 : 920MHz Band 3 When selecting B02 : 868MHz Band 3 When selecting B03 : 902MHz Band	
Receiving Sensitivity	-85dBm(25°C)	
Number of Receivable Connections (Number of Wireless Sensing Clamps / Linear Cylinders Connected)	Up to 4 units	Up to 8 units
Response Time	≤100msec (from wireless detection to state output)	
Number of Simultaneous Wireless Signals Received	1	
Power Supply	DC24V±20% 0.6A	
Operating Temperature and Humidity	-10°C ~ 60°C • 90% or less (at 40°C)	
Storage Temperature and Humidity	-20°C ~ 70°C • 90% or less (at 60°C)	
Clamping State Output	Number of Outputs	4 (M12 Coding A 12 pins)
	Output Attributes	4-output collective common (PNP/NPN switchable)
Output	Output Ratings	MAX DC24V±10% 0.45A
	Output Protection	Built-in overvoltage and overcurrent protection elements
	Number of Inputs	1 (M12 Coding A 4 pins)
Clamping State Reset Input	Input Terminals	Operation-end reset input by the signal linked with lock operation ON
	Input Attributes	External voltage input optocoupler (MAX DC24V)
Weight	500 g (including mounting bracket)	

External Dimensions

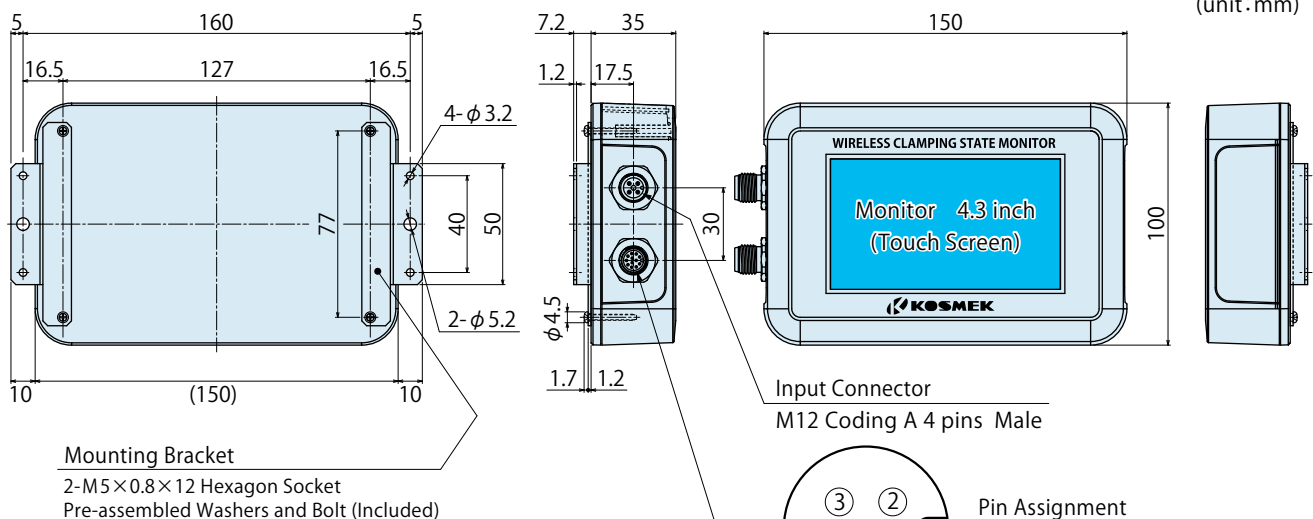

Regarding Connection Cable

Cables are not included.

Please prepare the cables by referring to the table below.

Connected to:	Cable-side Connector Shape (Customer Prepared side)	Reference: Cable Example (Oil-resistant, Waterproof Connector)
Input Connector	M12 Code A 4 pins Female	SAC-4P- 5,0-PUR/M12FS (manufactured by Phoenix Contact)
Output Connector	M12 Code A 12 pins Female	SAC-12P- 5,0-PUR/FS SCO (manufactured by Phoenix Contact)

Interface Diagram between Machine Tool and Receiver

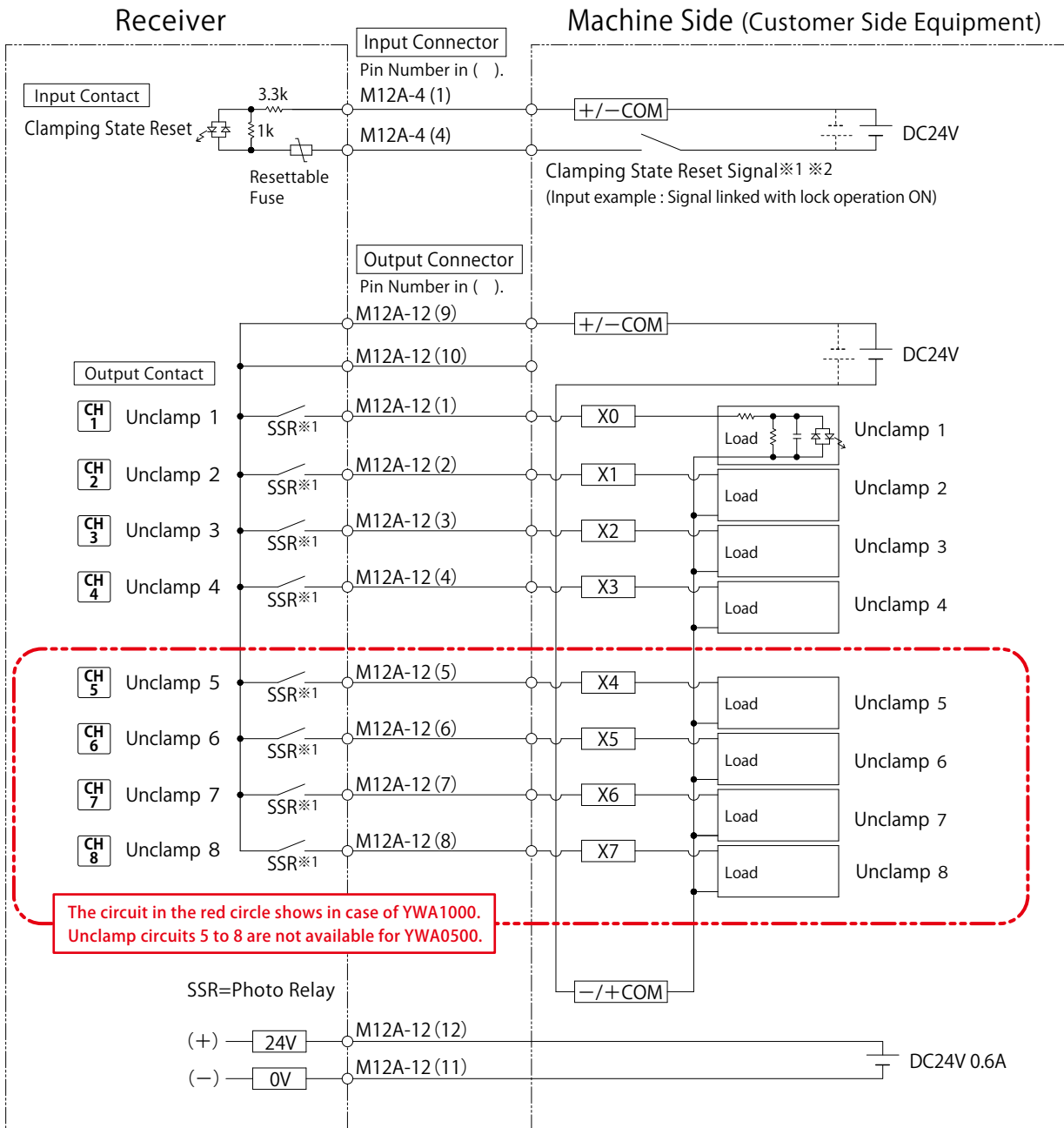

Notes :

1. If the receiver power is turned OFF (in case of power failure), 'Unclamp 1-4' (YWA0500), 'Unclamp 1-8' (YWA1000) will be OFF (contact open). When power is restored, reactivate clamps or linear cylinders to resume operation.
 2. If the clamps or linear cylinder inadvertently move from the operation ends, the corresponding unclamp signals will be turned OFF (contact open).
- *1. When switching the clamping state reset signal (ON→OFF or OFF→ON), 'Unclamp 1-4' (YWA0500), 'Unclamp 1-8' (YWA1000) will be OFF (contact open). Also, the operating time of the receiver will be reset to "0".
- *2. The clamping state reset signal is required in this system to ensure proper operating detection.

● Accessory (Sold Separately : Wall-Mounted Magnet)

Model No. Indication
YL0270

Design No.
 (Revision Number)

Model No.	No.	Name	Quantity
YL0270	①	Neodymium Magnet	2
	②	Phillips Head Countersunk Screw M3×0.5×8	4
	③	Hex Nut M3×0.5×8	4
	④	Spring Washer M3 JIS	4
	⑤	Flat Washer M3	4

YL0270 Mounting Dimensions (Unit:mm)

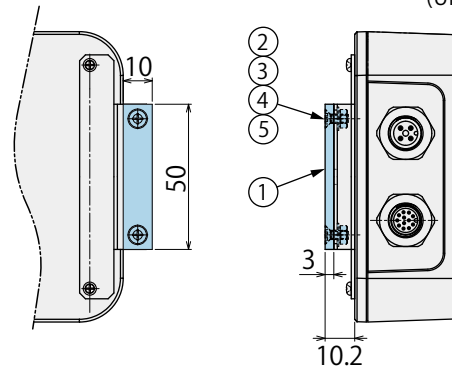

● Cautions for Receiver

1) Radio Regulations

There are restrictions on countries where the product can be used according to radio regulations.

Please follow the regulatory requirements of each country.

(Example) YWA0500/1000-B03-□ can be used in United States.

2) Please read the instruction manual carefully before designing and setting up.

Please contact us for the instruction manual.

- Screen Display and Operation Method

Please refer to the instruction manual for the screen display and operation method of the receiver.

- Initial Connection Settings

Initial connection settings are required to connect the receiver with the wireless sensing clamp/linear cylinder.

Please refer to the instruction manual for the setting method.

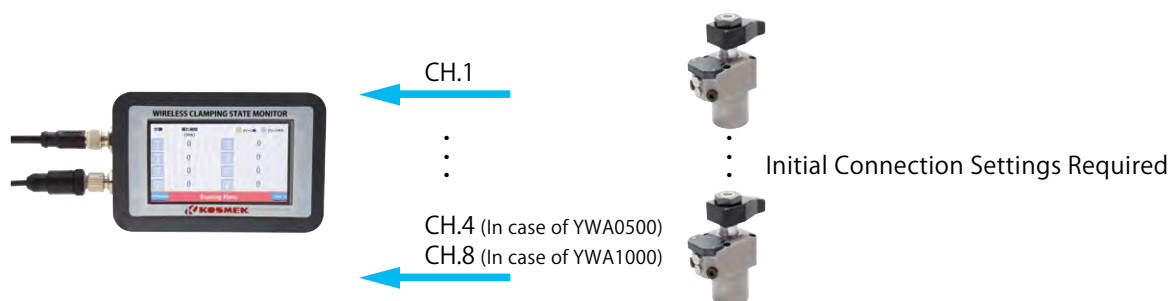

- Control Design and Electrical Circuit Design

Please check the operation timing chart in the instruction manual and design the appropriate control and electrical circuit.

- Repeater Configuration

After completing the initial connection settings between the clamp/linear cylinder and the receiver, please proceed with the settings for the receiver and the repeater.

Please refer to the instruction manual for the configuration method.

3) Cautions for Repeater Installation

- The maximum distance between the clamp and the receiver is 5 meters.

Check the radio wave strength displayed on the receiver and consider the installation of the repeater.

(Recommended Threshold : -85dBm)

- It is recommended to install the repeater in locations such as the upper part inside the processing machine, where it is less likely to be exposed to coolant or chips.

[Guidelines for Repeater Installation]

- When the receiver cannot be installed at a height of 2 meters or more.

- When there is a radio wave obstruction between the clamp/linear cylinder and the receiver.

- When the clamp/linear cylinder and the receiver are more than 3 meters apart.

※ Please refer to P.9 for common cautions.

• Notes on Handling

• Maintenance/Inspection

• Warranty

● Specifications : Repeater model YWB1000-B□

This repeater receives wireless signals for unclamp and stroke-end confirmation from the wireless sensing clamp (model LHM / LKM / LLM / LGM / LJM / WHP / WCP), amplifies the radio signal strength, and transmits them to the receiver (model YWA).



Model No.	YWB1000-B□	
Receiving Frequency	3	When selecting B01 : 920MHz Band
	3	When selecting B02 : 868MHz Band
	3	When selecting B03 : 902MHz Band
Receiving Sensitivity	-85dBm(25°C)	
Number of Simultaneous Wireless Connections	1	
Operating Temperature and Humidity	-10°C ~ 60°C • 90% or less (at 40°C)	
Storage Temperature and Humidity	-20°C ~ 70°C • 90% or less (at 60°C)	
Power Input	Connector	M12 Coding A 4 pins
	Power	DC24V±20% 0.3A
Weight	300g	
Waterproof Rating	Equivalent to IPX7 (when the housing is completely closed and a waterproof connector is attached)	

External Dimensions

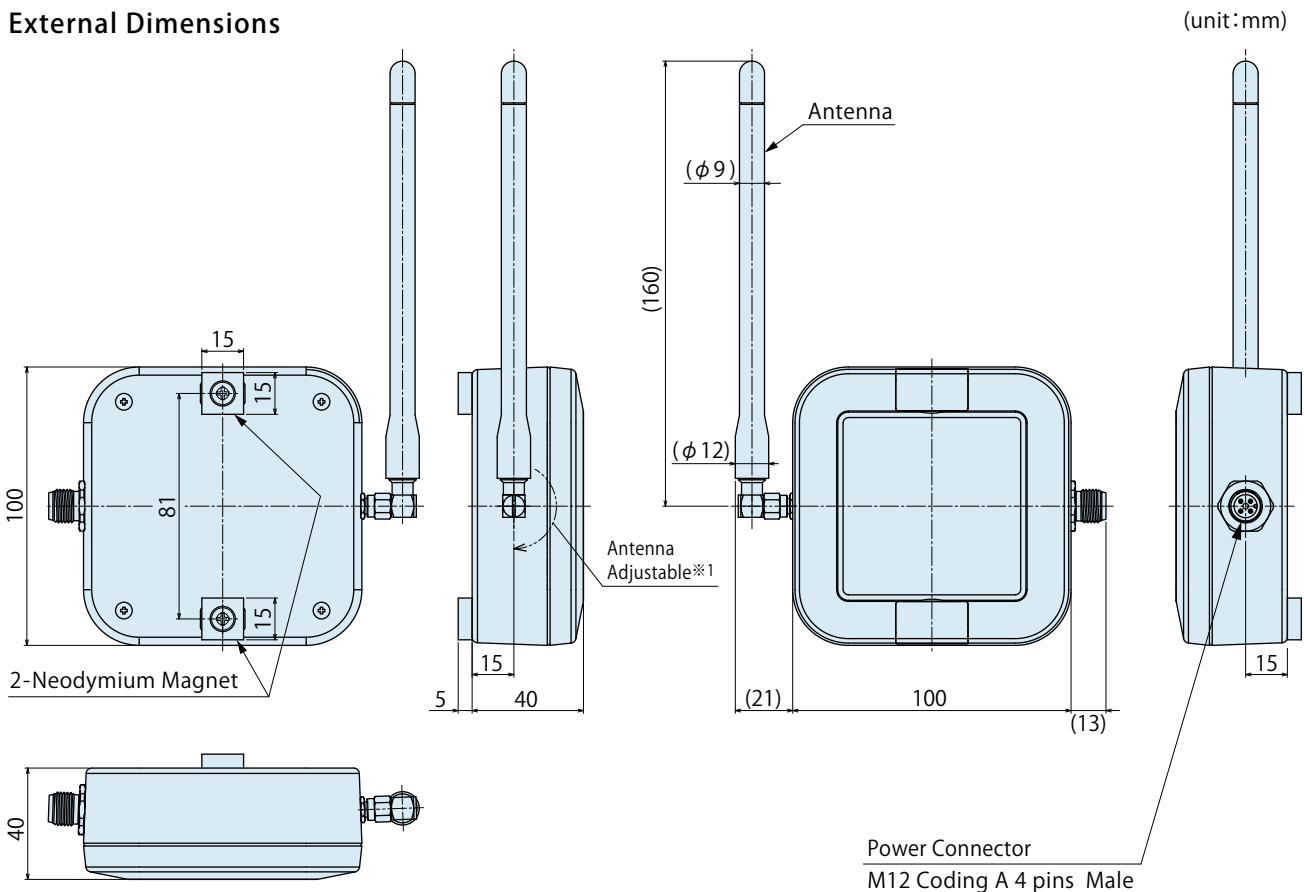

Note :

※1. Loosen the nut to change the direction of the antenna.

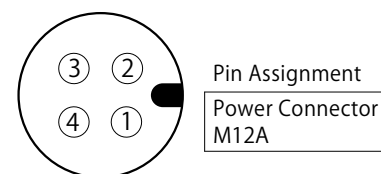

Regarding Connection Cable

Cables are not included.

Please prepare the cables by referring to the table below.

Connected to:	Cable-side Connector Shape (Customer Prepared side)	Reference: Cable Example (Oil-resistant, Waterproof Connector)
Power Connector	M12 Code A 4 pins Female	SAC-4P- 5,0-PUR/M12FS (manufactured by Phoenix Contact)

Interface Diagram of Repeater

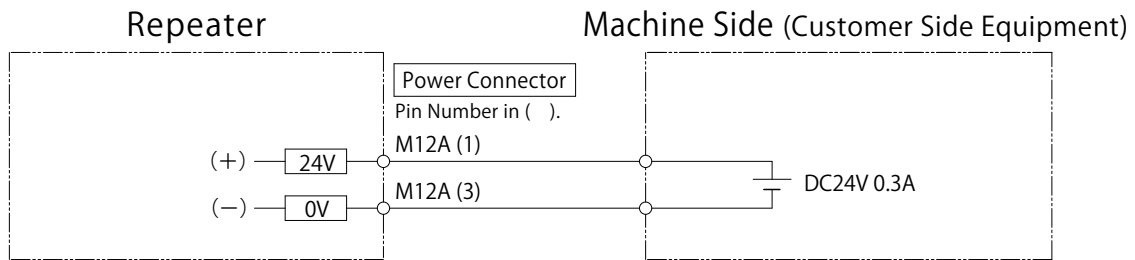

Cautions for Repeater

1. Radio Regulations

There are restrictions on countries where the product can be used according to radio regulations. Please follow the regulatory requirements of each country. (Ex.) YWB1000-B03 can be used in United States.

2. Repeater Configuration

After completing the initial connection settings between the clamp/linear cylinder and the receiver, please proceed with the settings for the receiver and the repeater. Please refer to the instruction manual of the receiver YWA for the configuration method.

3. Cautions for Repeater Installation

- The maximum distance between the clamp and the receiver is 5 meters. Check the radio wave strength displayed on the receiver and consider the installation of the repeater. (Recommended Threshold : -85dBm) It is recommended to install the repeater in locations such as the upper part inside the processing machine, where it is less likely to be exposed to coolant or chips.

[Guidelines for Repeater Installation]

- When the receiver cannot be installed at a height of 2 meters or more.
- When there is a radio wave obstruction between the clamp/linear cylinder and the receiver.
- When the clamp/linear cylinder and the receiver are more than 3 meters apart.

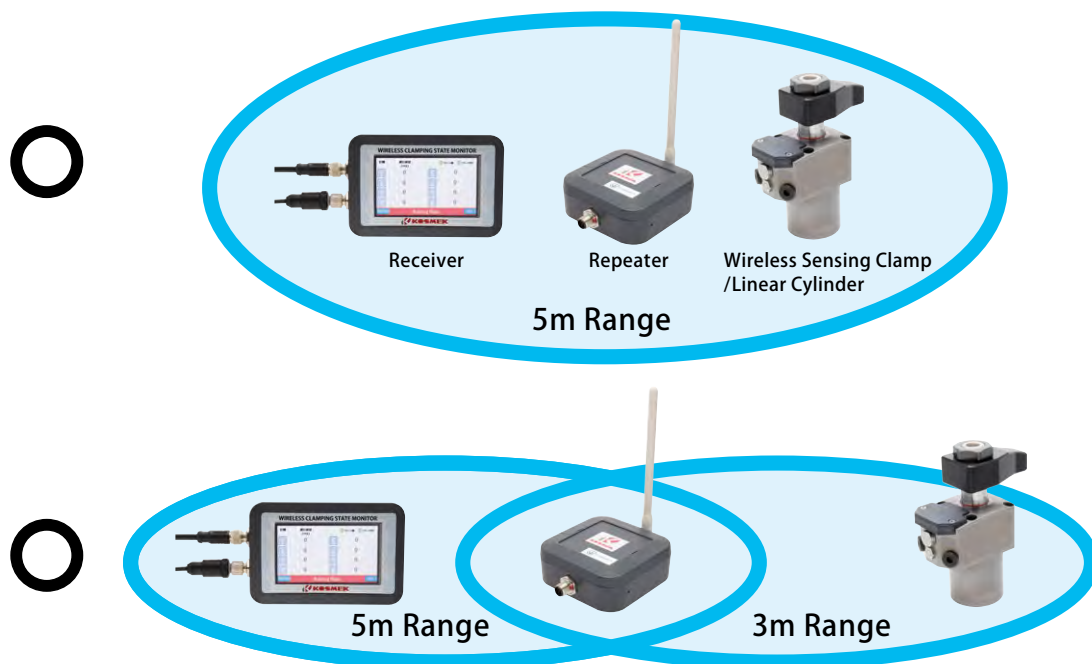

※ Please refer to P.9 for common cautions.

• Notes on Handling

• Maintenance/Inspection

• Warranty

ⓘ Cautions

● Notes on Handling

- 1) It should be operated by qualified personnel.
 - Machines and devices with hydraulic and pneumatic products should be operated and maintained by qualified personnel.
- 2) Do not operate or remove the product unless the safety protocols are ensured.
 - ① Machines and devices can only be inspected or prepared when it is confirmed that the safety devices are in place.
 - ② Before the product is removed, make sure that the above-mentioned safety devices are in place. Shut off the pressure and power source, and make sure no pressure exists in the air and hydraulic circuits.
 - ③ After stopping the product, do not remove until the temperature drops.
 - ④ Make sure there is no trouble/issue in the bolts and respective parts before restarting a machine or device.
- 3) Do not touch a clamp (cylinder) while it is working. Otherwise, your hands may be injured due to clinching.

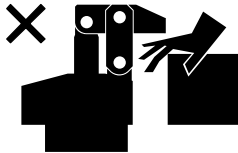

- 4) Do not disassemble or modify.
 - If the equipment is taken apart or modified, the warranty will be voided even within the warranty period.

● Maintenance and Inspection

- 1) Removal of the Machine and Shut-off of Pressure Source
 - Before the machine is removed, make sure that safety devices and preventive devices are in place. Shut off the pressure and power source, and make sure no pressure exists in the air and hydraulic circuits.
 - Make sure there is no abnormality in the bolts and respective parts before restarting.
- 2) Regularly clean the area around the piston rod.
 - If it is used when the surface is contaminated with dirt, it may lead to packing seal damage, malfunctioning and fluid leakage.

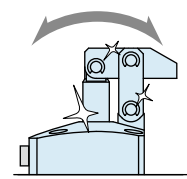
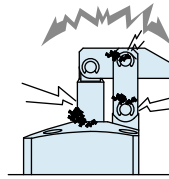

- 3) If disconnecting by couplers, air bleeding should be carried out on a regular basis to avoid air mixed in the circuit.
- 4) Regularly tighten pipe line, mounting bolt, nut, snap ring, cylinder and others to ensure proper use.
- 5) Make sure the hydraulic fluid has not deteriorated.
- 6) Make sure there is a smooth action without an irregular noise.
 - Especially when it is restarted after left unused for a long period, make sure it can be operated correctly.
- 7) The products should be stored in the cool and dark place without direct sunshine or moisture.
- 8) Please contact us for overhaul and repair.

● Warranty

1) Warranty Period

- The product warranty period is 18 months from shipment from our factory or 12 months from initial use, whichever is earlier.

2) Warranty Scope

- If the product is damaged or malfunctions during the warranty period due to faulty design, materials or workmanship, we will replace or repair the defective part at our expense.
Defects or failures caused by the following are not covered.
 - ① If the stipulated maintenance and inspection are not carried out.
 - ② If the product is used while it is not suitable for use based on the operator's judgment, resulting in defect.
 - ③ If it is used or operated in an inappropriate way by the operator.
(Including damage caused by the misconduct of the third party.)
 - ④ If the defect is caused by reasons other than our responsibility.
 - ⑤ If repair or modifications are carried out by anyone other than Kosmek, or without our approval and confirmation, it will void warranty.
 - ⑥ Other caused by natural disasters or calamities not attributable to our company.
 - ⑦ Parts or replacement expenses due to parts consumption and deterioration.
(Such as rubber, plastic, seal material and some electric components.)

Damages excluding from direct result of a product defect shall be excluded from the warranty.



KOSMEK LTD.

▶ <https://www.kosmek.com/>

HEAD OFFICE 1-5, 2-chome, Murotani, Nishi-ku, Kobe-city, Hyogo, Japan 651-2241
TEL.+81-78-991-5162 FAX.+81-78-991-8787

United States of America SUBSIDIARY	KOSMEK (USA) LTD. 650 Springer Drive, Lombard, IL 60148 USA TEL. +1-630-620-7650 FAX. +1-630-620-9015
MEXICO BRANCH OFFICE	KOSMEK USA MEXICO BRANCH OFFICE Av. Loma Pinal de Amoles 320-piso PH oficina 504 interior 13, Vista Dorada, 76060 Santiago de Querétaro, Qro. Mexico TEL. +52-442-851-1377
EUROPE SUBSIDIARY	KOSMEK EUROPE GmbH Schleppeplatz 2 9020 Klagenfurt am Wörthersee Austria TEL. +43-463-287587 FAX. +43-463-287587-20
CHINA SUBSIDIARY	KOSMEK (CHINA) LTD. Room601, RIVERSIDE PYRAMID No.55, Lane21, Pusan Rd, Pudong Shanghai 200125, China TEL. +86-21-54253000
INDIA BRANCH	KOSMEK LTD. - INDIA 4A/Old No:649, Ground Floor, 4th D cross, MM Layout, Kavalbyrasandra, RT Nagar, Bangalore -560032 India TEL.+91-9880561695
THAILAND REPRESENTATIVE OFFICE	KOSMEK Thailand Representation Office No.139, Blue Chips Building, 4th Floor, Room No.422, Soi Sukhumvit 63 (Thong Lor 10), Sukhumvit Road, Khlong Tan Nuea, Wattana, Bangkok 10110, Thailand TEL. +66(0)2-059-2010



WAHLTEC GmbH
T: +49 (7584) 9238883
F: +49 (7584) 9238887
kosmek@wahltec.de
www.wahltec.de

- For Further Information on Unlisted Specifications and Sizes, Please call us.
- Specifications in this Leaflet are Subject to Change without Notice.



JQA-QMA10823
KOSMEK HEAD OFFICE