

Pressure Balance Valve

Model BLB

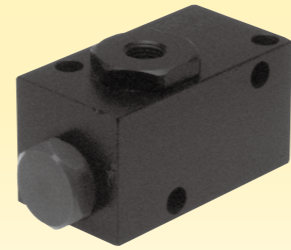

A pressure balance valve is actuated in sequence to prevent workpiece deformation

This valve prevents the deformation of workpiece when the work support releases.

• What is a pressure balance valve?

This valve prevents deformation of a workpiece during unclamping sequence. This will be useful when using work support and clamp actuator in opposite position.

When releasing, the incoming side pressure reduces around 1/20 of outgoing side pressure. Then outgoing side pressure start to reduce.

Circuit Symbol

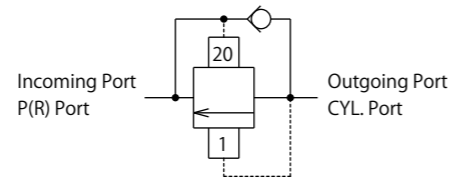

※ CYL. port comes with a built in filter.
Since a filter is not built in the P(R) port, please sufficiently perform flushing of piping and fitting to prevent foreign substances such as cutting chips from entering the circuit.

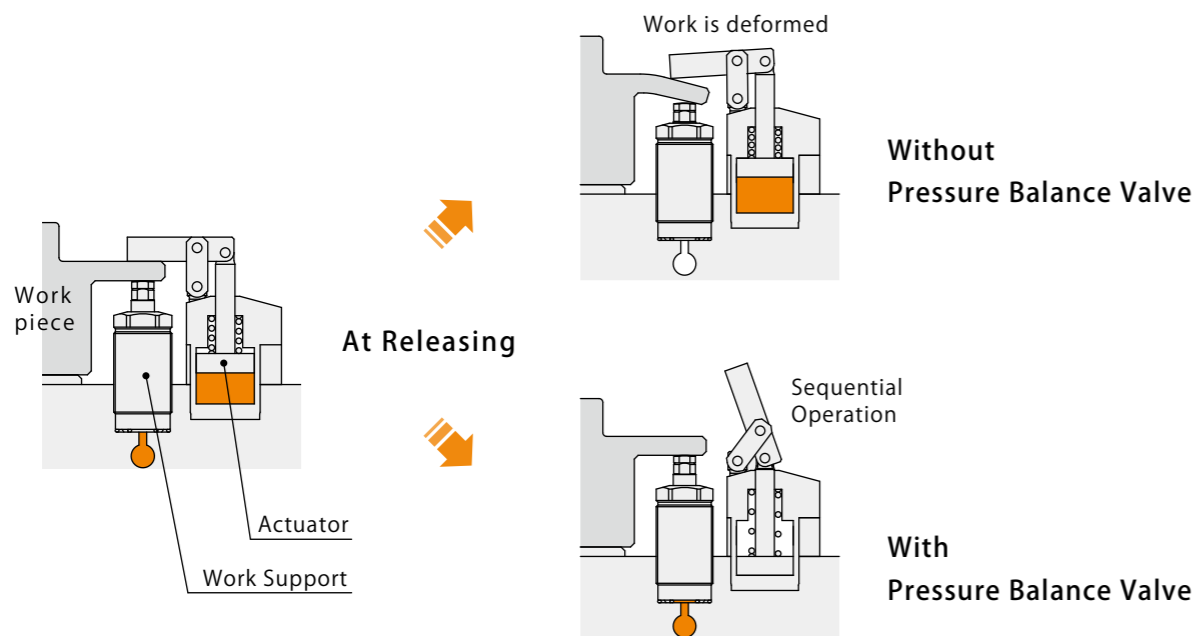

Action Description

Images

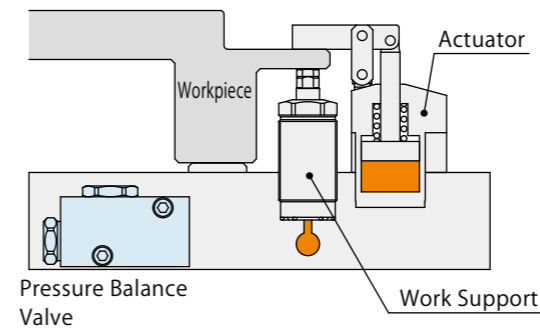

Circuit Example

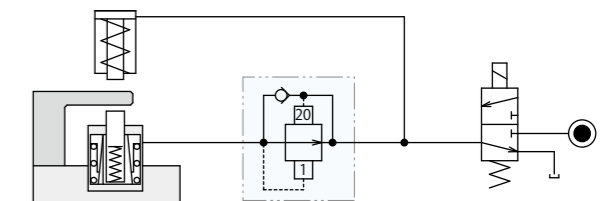
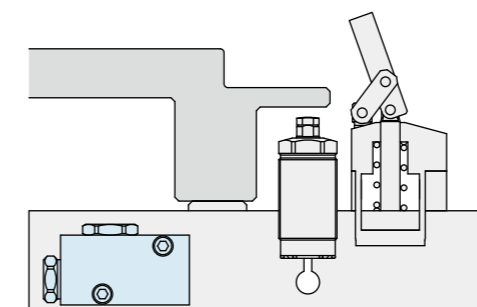
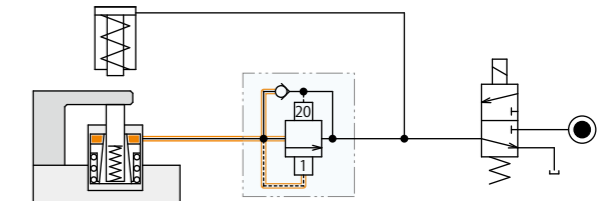
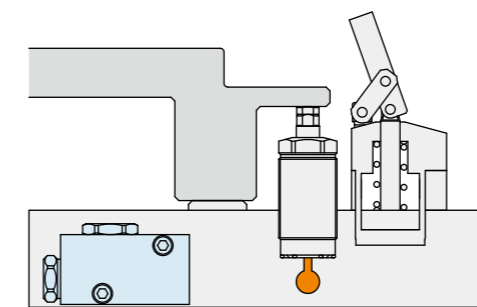
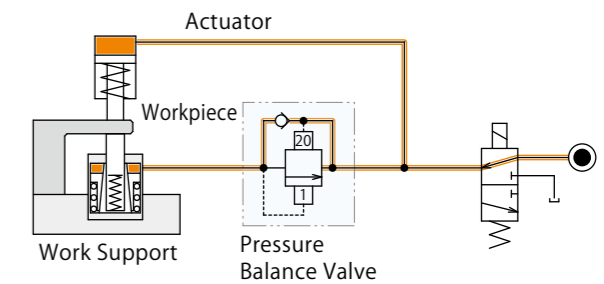

Operation Sequence		Remarks
When locking	Hydraulic pressure is ON.	
	The actuator and work support operates almost at the same time.	In the case that the work piece is deformed due to the actuator operating earlier than work support, use the sequence valve(BLS/BLG) or flow control valve in order to operate in sequence.
	Locking action completed.	
Machining process		
When releasing	Hydraulic pressure is OFF.	
	Actuator operates the release action.	
	The pressure balance valve circuit opens.	When incoming side pressure reduces up to around 1/20 of outgoing side pressure, circuit opens.
	Work Support is released.	
	Release action completed.	

- High-Power Series
- Pneumatic Series
- Hydraulic Series
- Valve / Coupler Hydraulic Unit**
- Manual Operation Accessories
- Cautions / Others

- Air Sequence Valve
- BWD

- Hydraulic Non-Leak Coupler
- BGA/BGB
- BGC/BGD
- BGP/BGS
- BBP/BBS
- BNP/BNS
- BJP/BJS
- BFP/BFS

- Auto Coupler
- JVA/JVB
- JVC/JVD
- JVE/JVF
- JNA/JNB
- JNC/JND
- JLP/JLS

- Rotary Joint
- JR

- Hydraulic Valve**
- BK
- BEQ
- BT
- BLS/BLG
- BLB**
- JSS/JS
- JKA/JKB
- BMA/BMG
- AU/AU-M
- BU
- BP/JPB
- BX
- BEP/BSP
- BH
- BC

- Air Hydraulic Unit
- CV
- CK
- CP/CPB
- CPC/CQC
- CB
- CC
- AB/AB-V
- AC/AC-V

Model No. Indication

BLB50 0 - 0

1 2

1 Design No.

0 : Revision Number

2 Piping Method

- Blank** : Piping Option (Rc Thread)
(Standard)
- W** : BK/BLS Connecting Option

Specifications

Model No.	BLB500-0 	
Operating Pressure Range	MPa	2.0 ~ 30.0
Withstanding Pressure	MPa	37.5
Min. Passage Area	mm ²	4.6
Operating Temperature	°C	0 ~ 70
Usable Fluid	General Hydraulic Oil Equivalent to ISO-VG-32	
Mass	kg	1.2

Note : 1. Please refer to BLS page for the example of a combination of BLG/BLS and BLB.

External Dimensions

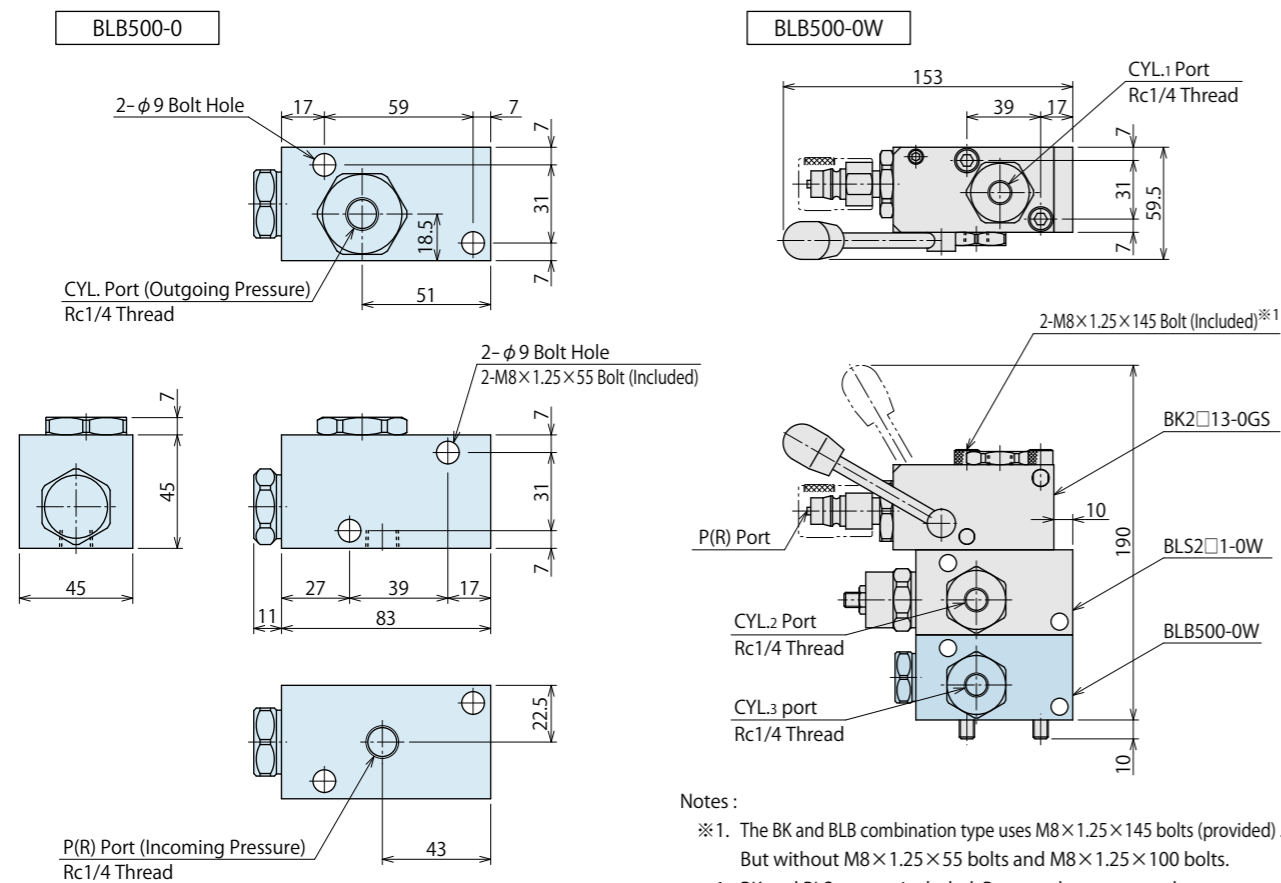

Notes :

※1. The BK and BLB combination type uses M8×1.25×145 bolts (provided).
But without M8×1.25×55 bolts and M8×1.25×100 bolts.

1. BK and BLS are not included. Prepare them separately.

MEMO

- High-Power Series
- Pneumatic Series
- Hydraulic Series
- Valve / Coupler Hydraulic Unit**
- Manual Operation Accessories
- Cautions / Others
- Air Sequence Valve
 - BWD
- Hydraulic Non-Leak Coupler
 - BGA/BGB
 - BGC/BGD
 - BGP/BGS
 - BBP/BBS
 - BNP/BNS
 - BJP/BJS
 - BFP/BFS
- Auto Coupler
 - JVA/JVB
 - JVC/JVD
 - JVE/JVF
 - JNA/JNB
 - JNC/JND
 - JLP/JLS
- Rotary Joint
 - JR
- Hydraulic Valve**
 - BK
 - BEQ
 - BT
 - BLS/BLG
 - BLB**
 - JSS/JS
 - JKA/JKB
 - BMA/BMG
 - AU/AU-M
 - BU
 - BP/JPB
 - BX
 - BEP/BSP
 - BH
 - BC
- Air Hydraulic Unit
 - CV
 - CK
 - CP/CPB
 - CPC/CQC
 - CB
 - CC
 - AB/AB-V
 - AC/AC-V

● Cautions

● Installation Notes (For Hydraulic Series)

- 1) Check the Usable Fluid
 - Please use the appropriate fluid by referring to the Hydraulic Fluid List.
- 2) Procedure before Piping
 - The pipeline, piping connector and fixture circuits should be cleaned by thorough flushing.
 - The dust and cutting chips in the circuit may lead to fluid leakage and malfunction.
 - There is no filter provided with Kosmek's product except for a part of valves which prevents foreign materials and contaminants from getting into the circuit.
- 3) Applying Sealing Tape
 - Wrap with tape 1 to 2 times following the screw direction.
 - Pieces of the sealing tape can lead to oil leakage and malfunction.
 - In order to prevent a foreign substance from going into the product during the piping work, it should be carefully cleaned before working.
- 4) Air Bleeding of the Hydraulic Circuit
 - If the hydraulic circuit has excessive air, the action time may become very long. If air enters the circuit after connecting the hydraulic port or under the condition of no air in the oil tank, please perform the following steps.
 - ① Reduce hydraulic pressure to less than 2MPa.
 - ② Loosen the cap nut of pipe fitting closest to the clamp by one full turn.
 - ③ Wiggle the pipeline to loosen the outlet of pipe fitting. Hydraulic fluid mixed with air comes out.

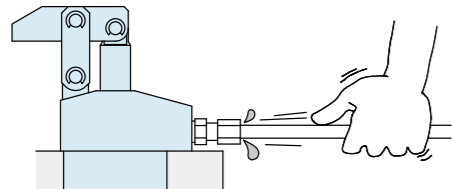

- ④ Tighten the cap nut after bleeding.
- ⑤ It is more effective to bleed air at the highest point inside the circuit or at the end of the circuit.
(Set an air bleeding valve at the highest point inside the circuit.)

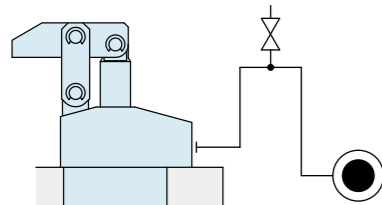

5) Checking Looseness and Retightening

- At the beginning of the machine installation, the bolt and nut may be tightened lightly. Check the looseness and re-tighten as required.

● Hydraulic Fluid List

Maker	ISO Viscosity Grade ISO-VG-32	
	Anti-Wear Hydraulic Oil	Multi-Purpose Hydraulic Oil
Showa Shell Sekiyu	Tellus S2 M 32	Morlina S2 B 32
Idemitsu Kosan	Daphne Hydraulic Fluid 32	Daphne Super Multi Oil 32
JX Nippon Oil & Energy	Super Hyrando 32	Super Mulpus DX 32
Cosmo Oil	Cosmo Hydro AW32	Cosmo New Mighty Super 32
ExxonMobil	Mobil DTE 24	Mobil DTE 24 Light
Matsumura Oil	Hydol AW-32	
Castrol	Hyspin AWS 32	

Note As it may be difficult to purchase the products as shown in the table from overseas, please contact the respective manufacturer.

● Notes on Hydraulic Cylinder Speed Control Unit

Please pay attention to the cautions below. Design the hydraulic circuit for controlling the action speed of hydraulic cylinder. Improper circuit design may lead to malfunctions and damages. Please review the circuit design in advance.

- Flow Control Circuit for Single Acting Cylinder
For spring return single acting cylinders, restricting flow during release can extremely slow down or disrupt release action. The preferred method is to control the flow during the lock action using a valve that has free-flow in the release direction. It is also preferred to provide a flow control valve at each actuator.

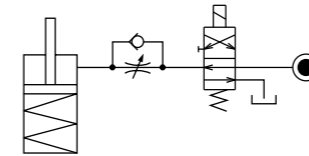

Accelerated clamping speed by excessive hydraulic flow to the cylinder may sustain damage. In this case add flow control to regulate flow. (Please add flow control to release flow if the lever weight is put on at the time of release action when using swing clamps.)

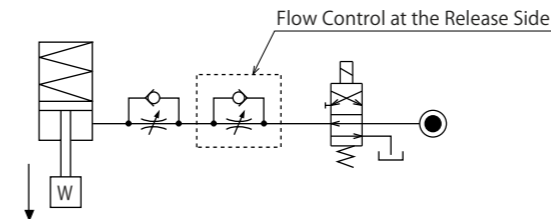

- Flow Control Circuit for Double Acting Cylinder
Flow control circuit for double acting cylinder should have meter-out circuits for both the lock and release sides. Meter-in control can have adverse effect by presence of air in the system. **However, in the case of controlling LKE, TMA, TLA, both lock side and release side should be meter-in circuit. Refer to P.75 for speed adjustment of LKE. For TMA and TLA, if meter-out circuit is used, abnormal high pressure is created, which causes oil leakage and damage.**

【Meter-out Circuit】 (Except LKE/TMA/TLA)

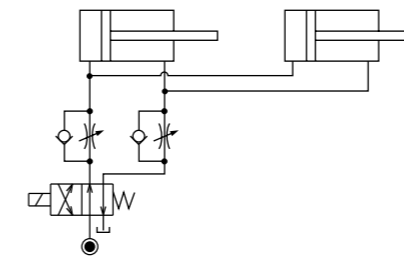

【Meter-in Circuit】 (LKE/TMA/TLA must be controlled with meter-in.)

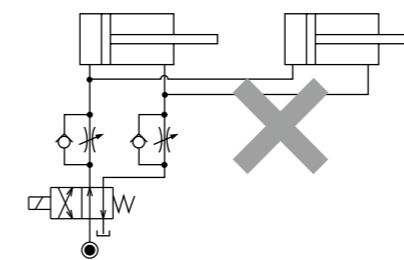

- ① Single acting components should not be used in the same flow control circuit as the double acting components. The release action of the single acting cylinders may become erratic or very slow.

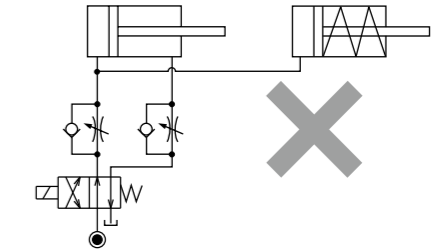

Refer to the following circuit when both the single acting cylinder and double acting cylinder are used together.
○ Separate the control circuit.

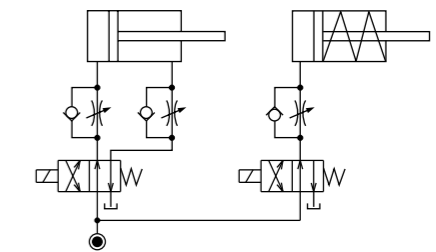

- Reduce the influence of double acting cylinder control unit. However, due to the back pressure in tank line, single action cylinder is activated after double action cylinder works.

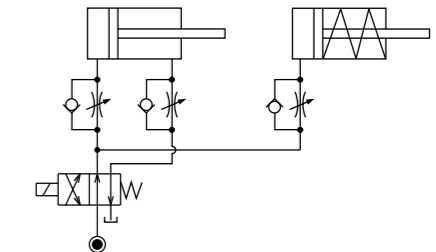

- ② In the case of meter-out circuit, the inner circuit pressure may increase during the cylinder action because of the fluid supply. The increase of the inner circuit pressure can be prevented by reducing the supplied fluid beforehand via the flow control valve. Especially when using sequence valve or pressure switches for clamping detection. If the back pressure is more than the set pressure then the system will not work as it is designed to.

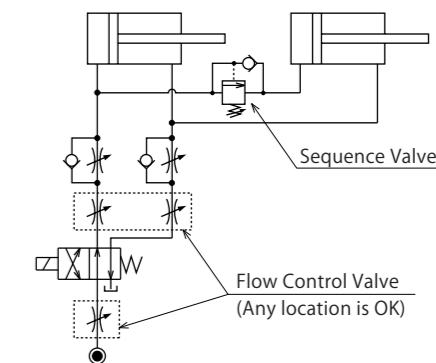

High-Power Series
Pneumatic Series
Hydraulic Series
Valve / Coupler Hydraulic Unit
Manual Operation Accessories
Cautions / Others

Cautions
Installation Notes (For Hydraulic Series)
Hydraulic Fluid List
Notes on Hydraulic Cylinder Speed Control Circuit
Notes on Handling
Maintenance/Inspection
Warranty

Company Profile
Company Profile
Our Products
History

Index
Search by Alphabetical Order

Sales Offices

Cautions

● Notes on Handling

- 1) It should be handled by qualified personnel.
 - The hydraulic machine and air compressor should be handled and maintained by qualified personnel.
- 2) Do not handle or remove the machine unless the safety protocols are ensured.
 - ① The machine and equipment can only be inspected or prepared when it is confirmed that the preventive devices are in place.
 - ② Before the machine is removed, make sure that the above-mentioned safety measures are in place. Shut off the air of hydraulic source and make sure no pressure exists in the hydraulic and air circuit.
 - ③ After stopping the machine, do not remove until the temperature cools down.
 - ④ Make sure there is no abnormality in the bolts and respective parts before restarting the machine or equipment.
- 3) Do not touch clamp (cylinder) while clamp (cylinder) is working. Otherwise, your hands may be injured due to clinching.

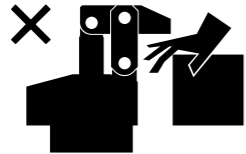

- 4) Do not disassemble or modify.
 - If the equipment is taken apart or modified, the warranty will be voided even within the warranty period.

● Maintenance and Inspection

- 1) Removal of the Machine and Shut-off of Pressure Source
 - Before the machine is removed, make sure that the above-mentioned safety measures are in place. Shut off the air of hydraulic source and make sure no pressure exists in the hydraulic and air circuit.
 - Make sure there is no abnormality in the bolts and respective parts before restarting.
- 2) Regularly clean the area around the piston rod and plunger.
 - If it is used when the surface is contaminated with dirt, it may lead to packing seal damage, malfunctioning, fluid leakage and air leaks.

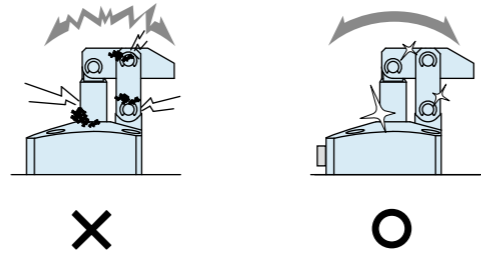

- 3) Please clean out the reference surface regularly (taper reference surface and seating surface) of locating machine. (VS/VT/VFL/VFM/VFJ/VFK/WVS/VWM/VWK/VX/VXF)
 - Location products, except VX/VXF model, can remove contaminants with cleaning functions. When installing pallets make sure there is no thick sludge like substances on pallets.
 - Continuous use with dirt on components will lead to locating functions not work properly, leaking and malfunction.

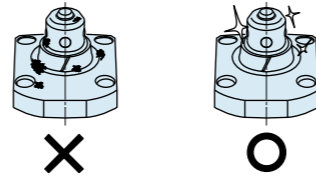

- 4) If disconnecting by couplers on a regular basis, air bleeding should be carried out daily to avoid air mixed in the circuit.
- 5) Regularly tighten nuts, bolts, pins, cylinders and pipe line to ensure proper use.
- 6) Make sure the hydraulic fluid has not deteriorated.
- 7) Make sure there is smooth action and no abnormal noise.
 - Especially when it is restarted after left unused for a long period, make sure it can be operated correctly.
- 8) The products should be stored in the cool and dark place without direct sunshine or moisture.
- 9) Please contact us for overhaul and repair.

● Warranty

- 1) Warranty Period
 - The product warranty period is 18 months from shipment from our factory or 12 months from initial use, whichever is earlier.
- 2) Warranty Scope
 - If the product is damaged or malfunctions during the warranty period due to faulty design, materials or workmanship, we will replace or repair the defective part at our expense. Defects or failures caused by the following are not covered.
 - ① If the stipulated maintenance and inspection are not carried out.
 - ② If the product is used while it is not suitable for use based on the operator's judgment, resulting in defect.
 - ③ If it is used or handled in inappropriate way by the operator. (Including damage caused by the misconduct of the third party.)
 - ④ If the defect is caused by reasons other than our responsibility.
 - ⑤ If repair or modifications are carried out by anyone other than Kosmek, or without our approval and confirmation, it will void warranty.
 - ⑥ Other caused by natural disasters or calamities not attributable to our company.
 - ⑦ Parts or replacement expenses due to parts consumption and deterioration. (Such as rubber, plastic, seal material and some electric components.)

Damages excluding from direct result of a product defect shall be excluded from the warranty.

- High-Power Series
- Pneumatic Series
- Hydraulic Series
- Valve / Coupler Hydraulic Unit
- Manual Operation Accessories
- Cautions / Others

- Cautions
 - Installation Notes (For Hydraulic Series)
 - Hydraulic Fluid List
 - Notes on Hydraulic Cylinder Speed Control Circuit
 - Notes on Handling
 - Maintenance/Inspection
 - Warranty

- Company Profile
 - Company Profile
 - Our Products
 - History

- Index
 - Search by Alphabetical Order

- Sales Offices