

1.5 ~ 25MPa

Double Acting

New

Hydraulic Linear Cylinder

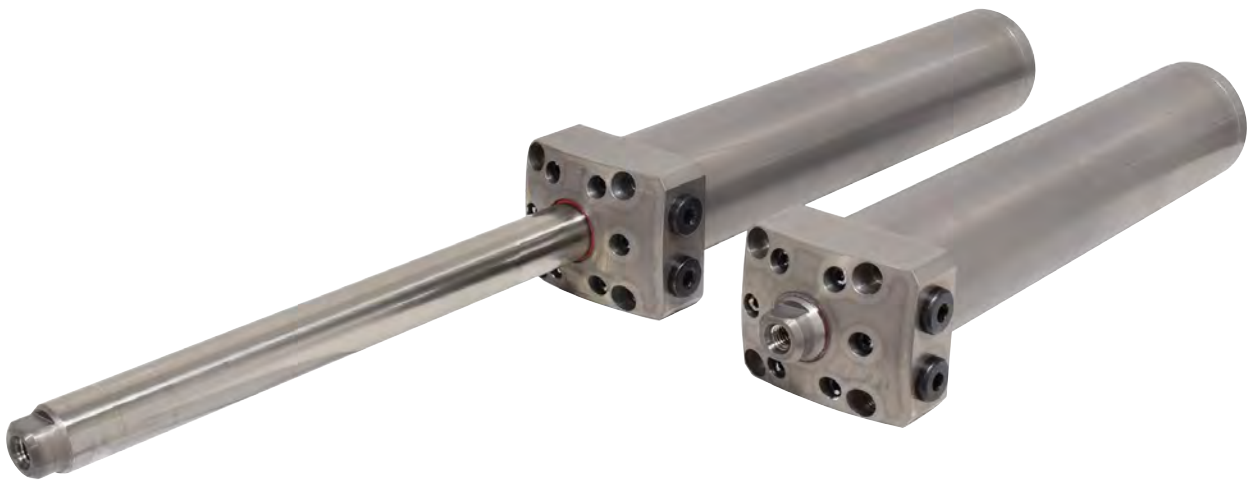

Model TTA

 **WAHLTEC**[®]
KNOWLEDGE | TRUST | SUCCESS

 **KOSMEK**
Harmony in Innovation

Linear Cylinder

Model TTA

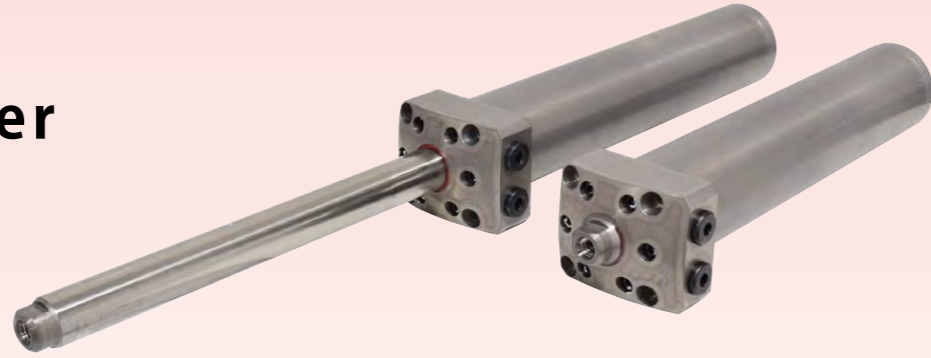

Compact and Simple Linear Cylinder



High Pressure (1.5 ~ 25MPa)

Able to set the stroke in 1mm increments.

● **High-Pressure Linear Cylinder (Double-Acting Linear Cylinder)**

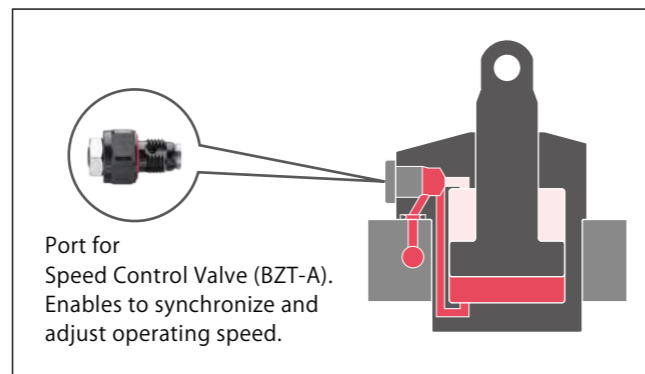
Stroke is selectable in 1mm increments (1mm ~ 200mm).
The most compact double-acting cylinders for small footprint fixtures.



Double-Acting Model MAX 25MPa	 Model TTA
Classification	Double-Acting Linear Cylinder
Operating Pressure Range	1.5 ~ 25MPa
Standard Model	External Dimensions → P.5
Accessories 	<ul style="list-style-type: none"> • Speed Control Valve (model BZT) → P.9 • G-Thread Fitting (model 9UK□) → P.11

● **Allowable Stroke Chart**

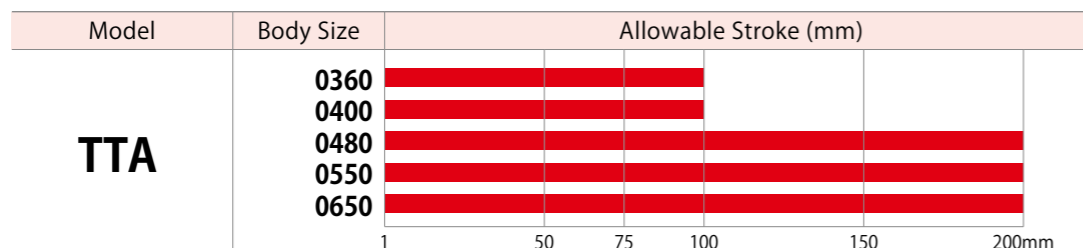

● **Application Examples**

As a Lifter

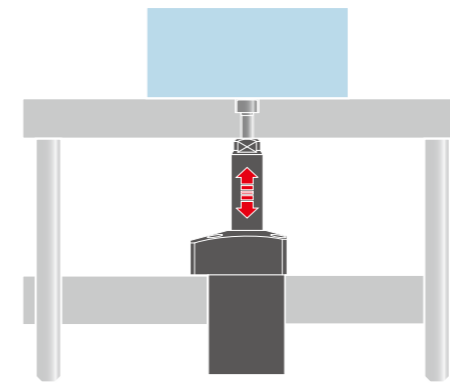

As a Shifter/Pusher

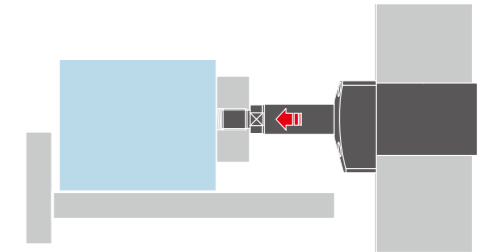

As a Clamp/Press-Fit

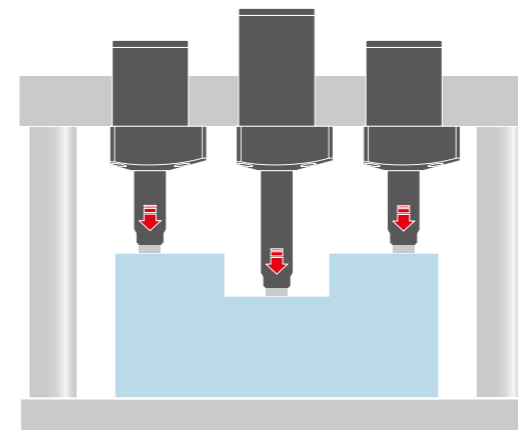

As a Link Mechanism

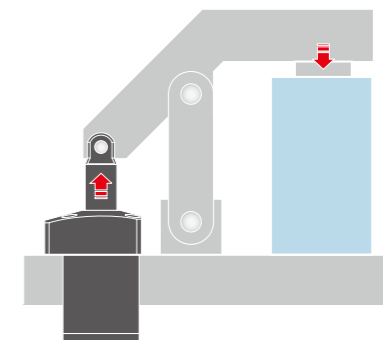

As a Slide Positioning Pin

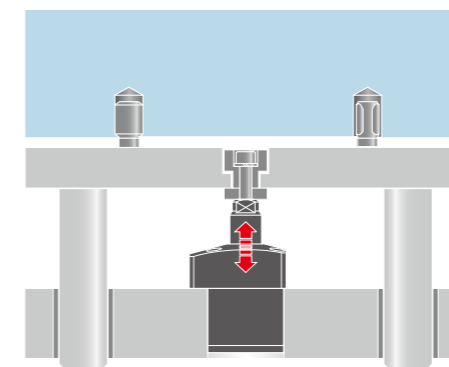

As a Pull Cylinder

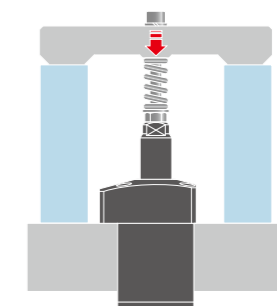



Model No. Indication

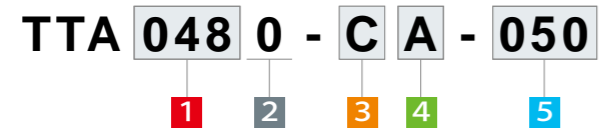

1 Body Size

- 036 : φD=36mm
 - 040 : φD=40mm
 - 048 : φD=48mm
 - 055 : φD=55mm
 - 065 : φD=65mm
- ※ Outer diameter (φD) of the cylinder.

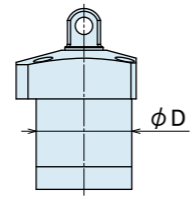

2 Design No.

0 : Revision Number

3 Piping Method

- C : Gasket Option (With G Thread Plug)
- ※ Speed control valve (BZT) is sold separately. Refer to the P.9 for detail.

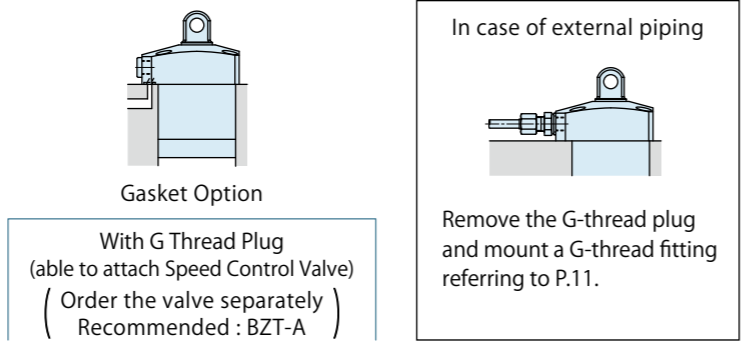

4 Shape of Piston Tip

- A : Female Threaded
- T : Male Threaded
- P : Pin-Hole Option

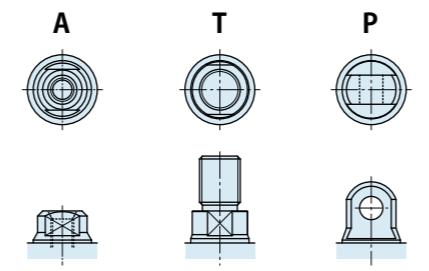

5 Stroke

Stroke Value : Full Stroke

※ Full stroke can be set in 1 mm increments within the allowable stroke range. (Refer to P.1.)
Example : Full Stroke of 1mm : 001
Full Stroke of 53mm : 053
Full Stroke of 175mm : 175

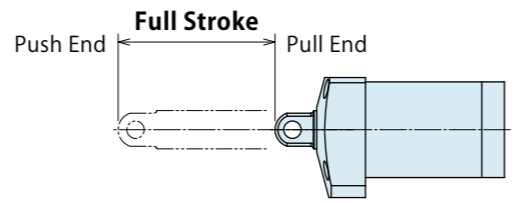

Performance Curve

Applicable Model

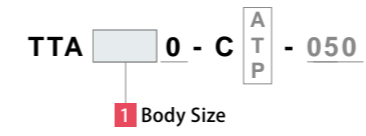

Max. Operating Pressure : 25 MPa
Min. Operating Pressure : 1.5 MPa

Body Size	Cylinder Inside Diameter (mm)	Rod Diameter (mm)	Cylinder Area (Push Side) (cm ²)	Cylinder Force (Push Side) Calculation Formula (kN) ^{※1}	Cylinder Area (Pull Side) (cm ²)	Cylinder Force (Pull Side) Calculation Formula (kN) ^{※1}
036	φ22	φ16	3.8	F = P × 0.38	1.8	F = P × 0.18
040	φ24	φ18	4.5	F = P × 0.45	2.0	F = P × 0.20
048	φ28	φ20	6.2	F = P × 0.62	3.0	F = P × 0.30
055	φ32	φ22	8.0	F = P × 0.80	4.2	F = P × 0.42
065	φ40	φ25	12.6	F = P × 1.26	7.7	F = P × 0.77

Body Size	Cylinder Force (Push Side) (kN)							Cylinder Force (Pull Side) (kN)						
	1.5MPa	3MPa	5MPa	10MPa	15MPa	20MPa	25MPa	1.5MPa	3MPa	5MPa	10MPa	15MPa	20MPa	25MPa
036	0.6	1.1	1.9	3.8	5.7	7.6	9.5	0.3	0.5	0.9	1.8	2.7	3.6	4.5
040	0.7	1.4	2.3	4.5	6.8	9.0	11.3	0.3	0.6	1.0	2.0	3.0	4.0	4.9
048	0.9	1.8	3.1	6.2	9.2	12.3	15.4	0.5	0.9	1.5	3.0	4.5	6.0	7.5
055	1.2	2.4	4.0	8.0	12.1	16.1	20.1	0.6	1.3	2.1	4.2	6.4	8.5	10.6
065	1.9	3.8	6.3	12.6	18.8	25.1	31.4	1.1	2.3	3.8	7.7	11.5	15.3	19.1

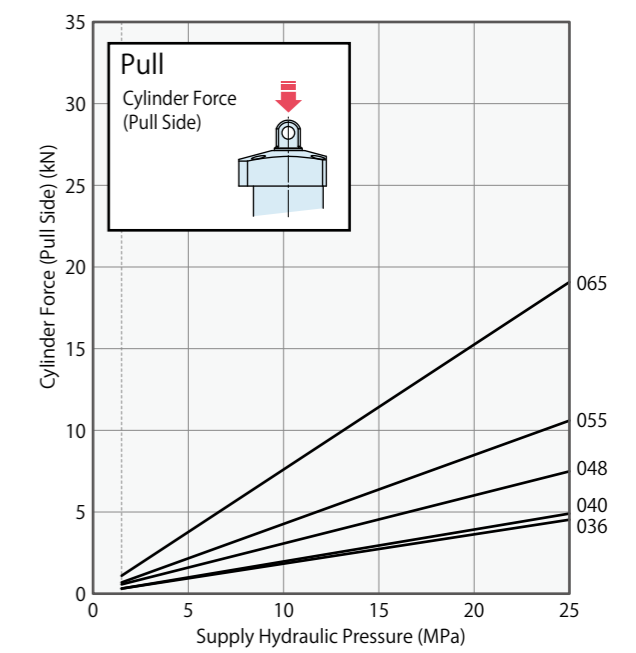
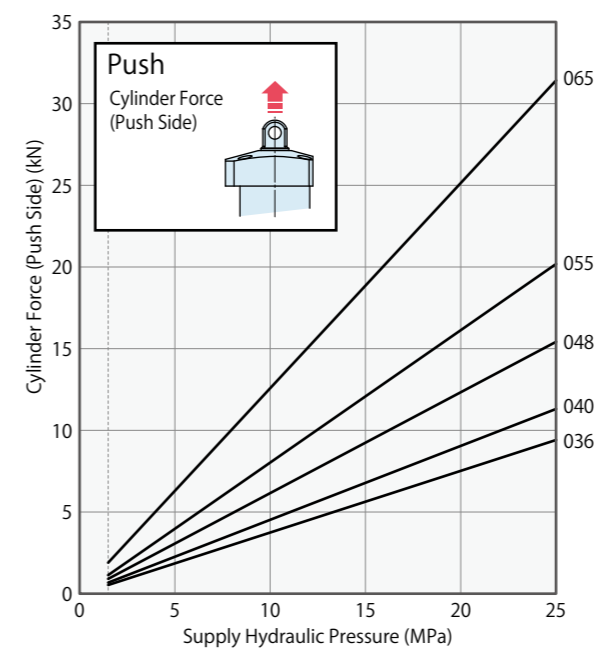

Notes :
 ※1. F : Cylinder Force (kN), P : Supply Hydraulic Pressure (MPa)
 1. Tables and graphs show the relationship between the cylinder output and the supply hydraulic pressure.
 2. Cylinder Force F (kN) is the theoretical value. Actual output may decrease because of friction and pressure loss.

External Dimensions

[P] : Pin-Hole Option

※This drawing shows TTA-CP.

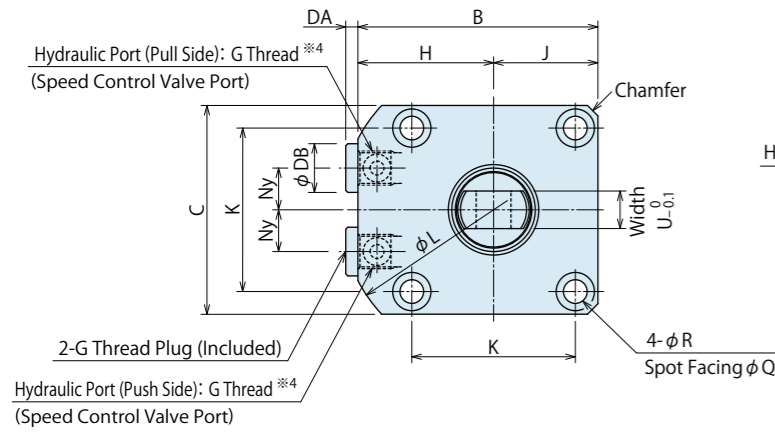

Machining Dimensions of Mounting Area

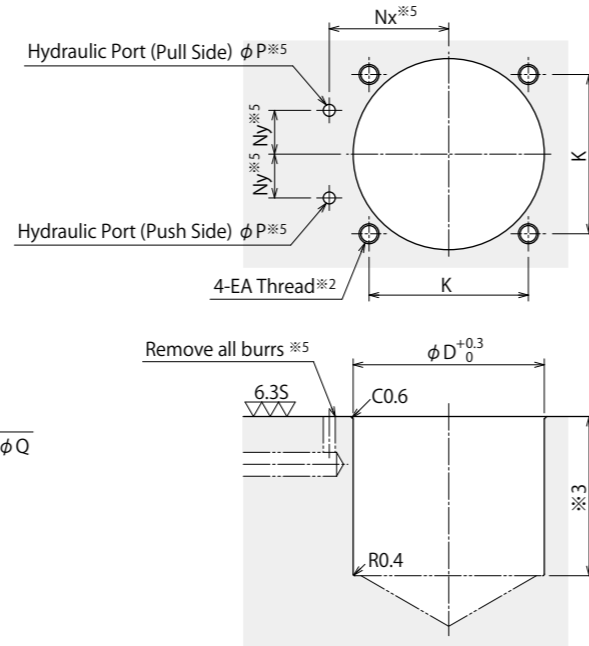

Specifications

Model No.	TTA0360-C□-□	TTA0400-C□-□	TTA0480-C□-□	TTA0550-C□-□	TTA0650-C□-□
Full Stroke Y	Y : 1 ~ 50			Y : 1 ~ 75	
Cylinder Area cm ²	Push Side	3.8	4.5	6.2	12.6
	Pull Side	1.8	2.0	3.0	7.7
Cylinder Force (Calculation Formula) kN	Push Side	P×0.38	P×0.45	P×0.62	P×1.26
	Pull Side	P×0.18	P×0.20	P×0.30	P×0.77
Cylinder Capacity (Calculation Formula) cm ³	Push Side	Y×0.38	Y×0.45	Y×0.62	Y×1.26
	Pull Side	Y×0.18	Y×0.20	Y×0.30	Y×0.77
Cylinder Inner Diameter	mm	φ22	φ24	φ28	φ32
Rod Diameter	mm	φ16	φ18	φ20	φ22
Max. Operating Pressure	MPa	25			
Min. Operating Pressure	MPa	1.5			
Withstanding Pressure	MPa	37.5			
Operating Temperature	°C	0 ~ 70			
Usable Fluid	General Hydraulic Oil Equivalent to ISO-VG-32				
Weight	kg	0.6 ~ 0.8	0.7 ~ 1.0	1.1 ~ 1.8	1.5 ~ 2.5

P : Supply Hydraulic Pressure (MPa), Y : Full Stroke (mm)

External Dimensions and Machining Dimensions for Mounting

※ When Full Stroke Y is 1~14mm: the same external dimensions as Stroke = 15mm.
(Ex.) TTA0360-CP-010 [Y=10, A=66.5, E=50, F=25]
TTA0360-CP-030 [Y=30, A=81.5, E=65, F=40]

[P] : Pin-Hole Option

Model No.	TTA0360-CP-□		TTA0400-CP-□		TTA0480-CP-□		TTA0550-CP-□		TTA0650-CP-□	
Full Stroke Y	1 ~ 14	15 ~ 50	1 ~ 14	15 ~ 50	1 ~ 14	15 ~ 75	1 ~ 14	15 ~ 75	1 ~ 14	15 ~ 75
A	66.5	Y+51.5	72	Y+57	82	Y+67	89	Y+74	101	Y+86
B	50.5		54		61		69		81	
C	40		45		51		60		70	
D	36		40		48		55		65	
E	50	Y+35	53	Y+38	61	Y+46	65	Y+50	72	Y+57
F	25	Y+10	27	Y+12	33	Y+18	37	Y+22	42	Y+27
G	25		26		28		28		30	
H	30.5		31.5		35.5		39		46	
J	20		22.5		25.5		30		35	
K	31.4		34		40		47		55	
L	68.5		73		83		88		106	
M	11		11		12		12		13	
Nx	25		26		30		33.5		39.5	
Ny	8.5		9		11		12		15	
P	3		3		3		3		5	
Q	7.5		9.5		9.5		11		11	
R	4.3		5.5		5.5		6.8		6.8	
S	16		15.5		15.5		13		15.5	
T	16.5		19		21		24		29	
U	7.8		9.8		9.8		10.8		12.8	
V	6.5		8		9		10		13	
W	8.5		9.5		10.5		12		14	
Chamfer	C2		C3		C3		C3		C4	
AB	13		15		17		19		22	
AC	6 ^{+0.012} ₀		8 ^{+0.015} ₀		8 ^{+0.015} ₀		10 ^{+0.015} ₀		12 ^{+0.018} ₀	
AD	6.5		8		9		10		13	
DA	3		3		3		3		3.5	
DB	14		14		14		14		19	
EA	M4×0.7		M5×0.8		M5×0.8		M6×1		M6×1	
Hydraulic Port	G1/8		G1/8		G1/8		G1/8		G1/4	
O-ring	1BP5		1BP5		1BP5		1BP5		1BP7	

Tip Shape

Refer to [P] Pin-Hole Option for unlisted dimensions.

[A] : Female Threaded

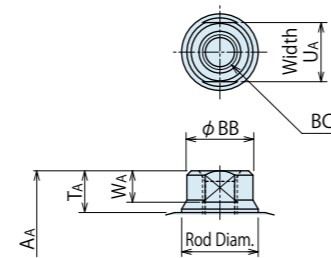

[T] : Male Threaded

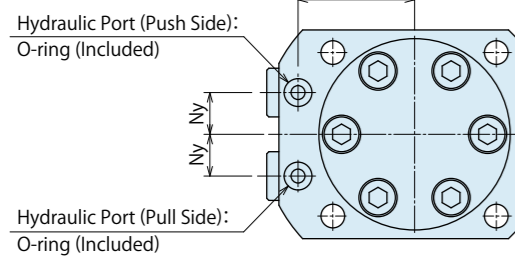
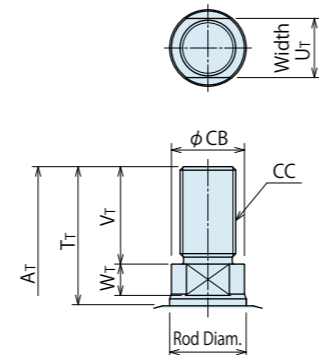

Notes :

- ※1. Mounting bolts are not provided. Please prepare them according to the mounting height referring to dimension 'S'.
- ※2. EA tapping depth of the mounting bolt should be decided according to the mounting height referring to dimension 'S'.
- ※3. The depth of the body mounting hole φD should be decided according to the mounting height referring to dimension 'F'.
- ※4. Speed control valve is not provided. Please refer to P.9.
- ※5. In case of removing the G-thread plug and supplying hydraulic pressure with external piping, this machining is not required.

[A] : Female Threaded

Refer to P Pin-Hole Option for unlisted dimensions. (mm)

Model No.	TTA0360-CA-□	TTA0400-CA-□	TTA0480-CA-□	TTA0550-CA-□	TTA0650-CA-□					
A _A	59	Y+44	63	Y+48	72	Y+57	77	Y+62	85	Y+70
T _A	9		10		11		12		13	
U _A	13		13		16		17		19	
W _A	7.5		7.5		9		9		10	
BB	15		15		18		19		22	
BC (Nominal×Pitch×Depth)	M8×1.25×16		M8×1.25×16		M10×1.5×20		M10×1.5×20		M12×1.75×24	

[T] : Male Threaded

Refer to P Pin-Hole Option for unlisted dimensions. (mm)

Model No.	TTA0360-CT-□	TTA0400-CT-□	TTA0480-CT-□	TTA0550-CT-□	TTA0650-CT-□					
A _T	78	Y+63	83	Y+68	96	Y+81	105	Y+90	117	Y+102
T _T	28		30		35		40		45	
U _T	12		14		17		17		19	
V _T	18		20		24		28		32	
W _T	7.5		7.5		8.5		9		10	
CB	15		17		19		21		24	
CC (Nominal×Pitch)	M10×1.25		M12×1.25		M14×1.5		M16×1.5		M20×1.5	

External Dimensions

[P] : Pin-Hole Option

※This drawing shows TTA-CP.

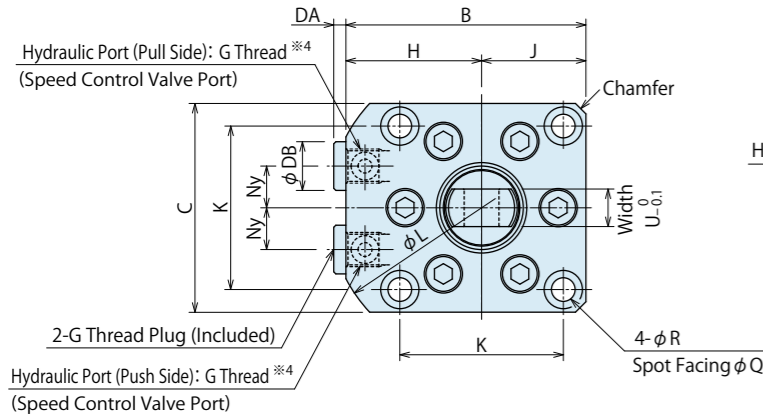

Machining Dimensions of Mounting Area

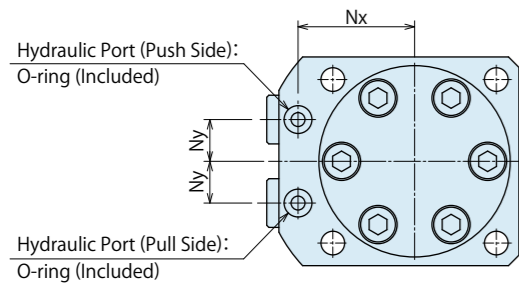
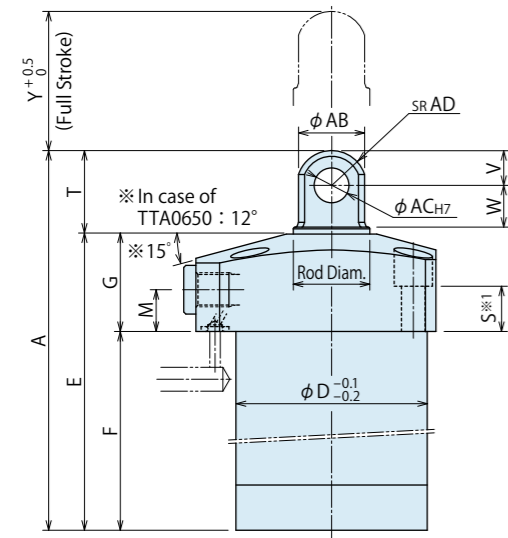
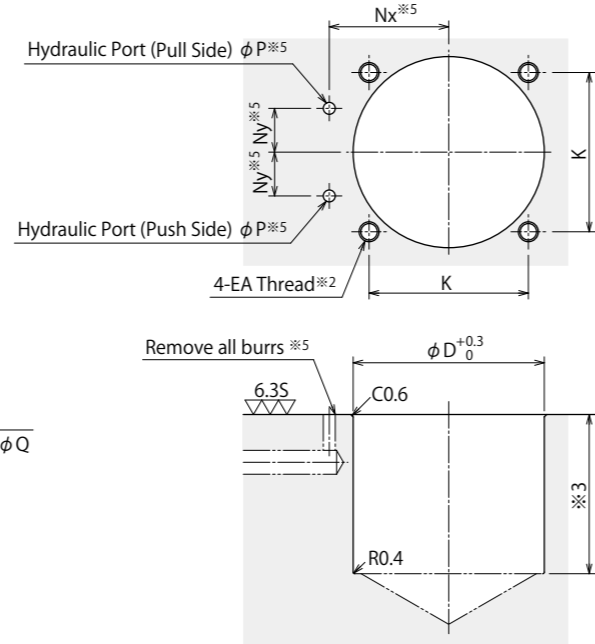

Tip Shape

Refer to [P] Pin-Hole Option for unlisted dimensions.

[A] : Female Threaded

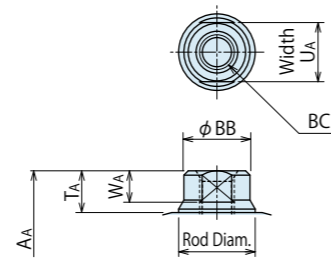

[T] : Male Threaded

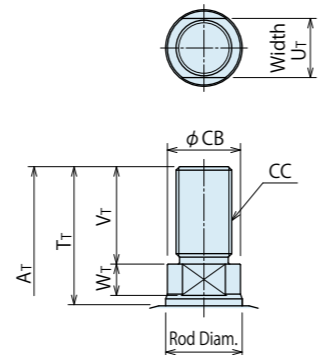

Notes :

- ※1. Mounting bolts are not provided. Please prepare them according to the mounting height referring to dimension 'S'.
- ※2. EA tapping depth of the mounting bolt should be decided according to the mounting height referring to dimension 'S'.
- ※3. The depth of the body mounting hole ϕD should be decided according to the mounting height referring to dimension 'F'.
- ※4. Speed control valve is not provided. Please refer to P.9.
- ※5. In case of removing the G-thread plug and supplying hydraulic pressure with external piping, this machining is not required.

Specifications

Model No.	TTA0360-C□-□	TTA0400-C□-□	TTA0480-C□-□	TTA0550-C□-□	TTA0650-C□-□
Full Stroke Y	Y : 51 ~ 100			Y : 76 ~ 200	
Cylinder Area cm ²	Push Side	3.8	4.5	6.2	12.6
	Pull Side	1.8	2.0	3.0	7.7
Cylinder Force (Calculation Formula) kN	Push Side	P×0.38	P×0.45	P×0.62	P×0.80
	Pull Side	P×0.18	P×0.20	P×0.30	P×0.42
Cylinder Capacity (Calculation Formula) cm ³	Push Side	Y×0.38	Y×0.45	Y×0.62	Y×0.80
	Pull Side	Y×0.18	Y×0.20	Y×0.30	Y×0.42
Cylinder Inner Diameter	mm	$\phi 22$	$\phi 24$	$\phi 28$	$\phi 32$
Rod Diameter	mm	$\phi 16$	$\phi 18$	$\phi 20$	$\phi 25$
Max. Operating Pressure	MPa	25			
Min. Operating Pressure	MPa	1.5			
Withstanding Pressure	MPa	37.5			
Operating Temperature	°C	0 ~ 70			
Usable Fluid	General Hydraulic Oil Equivalent to ISO-VG-32				
Weight	kg	0.9 ~ 1.2	1.2 ~ 1.6	2.0 ~ 3.5	2.7 ~ 4.6

P : Supply Hydraulic Pressure (MPa), Y : Full Stroke (mm)

External Dimensions and Machining Dimensions for Mounting

[P] : Pin-Hole Option

(Ex.) TTA0360-CP-020 [Y=70, A=136.5, E=120, F=95]

(mm)

Model No.	TTA0360-CP-□	TTA0400-CP-□	TTA0480-CP-□	TTA0550-CP-□	TTA0650-CP-□
Full Stroke Y	51 ~ 100	51 ~ 100	76 ~ 200	76 ~ 200	76 ~ 200
A	Y+66.5	Y+72	Y+82	Y+88	Y+98.5
B	50.5	54	61	69	81
C	40	45	51	60	70
D	36	40	48	55	65
E	Y+50	Y+53	Y+61	Y+64	Y+69.5
F	Y+25	Y+27	Y+33	Y+36	Y+39.5
G	25	26	28	28	30
H	30.5	31.5	35.5	39	46
J	20	22.5	25.5	30	35
K	31.4	34	40	47	55
L	68.5	73	83	88	106
M	11	11	12	12	13
Nx	25	26	30	33.5	39.5
Ny	8.5	9	11	12	15
P	3	3	3	3	5
Q	7.5	9.5	9.5	11	11
R	4.3	5.5	5.5	6.8	6.8
S	16	15.5	15.5	13	15.5
T	16.5	19	21	24	29
U	7.8	9.8	9.8	10.8	12.8
V	6.5	8	9	10	13
W	8.5	9.5	10.5	12	14
Chamfer	C2	C3	C3	C3	C4
AB	13	15	17	19	22
AC	6 ^{+0.012} ₀	8 ^{+0.015} ₀	8 ^{+0.015} ₀	10 ^{+0.015} ₀	12 ^{+0.018} ₀
AD	6.5	8	9	10	13
DA	3	3	3	3	3.5
DB	14	14	14	14	19
EA	M4×0.7	M5×0.8	M5×0.8	M6×1	M6×1
Hydraulic Port	G1/8	G1/8	G1/8	G1/8	G1/4
O-ring	1BP5	1BP5	1BP5	1BP5	1BP7

[A] : Female Threaded

Refer to P Pin-Hole Option for unlisted dimensions. (mm)

Model No.	TTA0360-CA-□	TTA0400-CA-□	TTA0480-CA-□	TTA0550-CA-□	TTA0650-CA-□
A _A	Y+59	Y+63	Y+72	Y+76	Y+82.5
T _A	9	10	11	12	13
U _A	13	13	16	17	19
W _A	7.5	7.5	9	9	10
BB	15	15	18	19	22
BC (Nominal×Pitch×Depth)	M8×1.25×16	M8×1.25×16	M10×1.5×20	M10×1.5×20	M12×1.75×24

[T] : Male Threaded

Refer to P Pin-Hole Option for unlisted dimensions. (mm)

Model No.	TTA0360-CT-□	TTA0400-CT-□	TTA0480-CT-□	TTA0550-CT-□	TTA0650-CT-□
A _T	Y+78	Y+83	Y+96	Y+104	Y+114.5
T _T	28	30	35	40	45
U _T	12	14	17	17	19
V _T	18	20	24	28	32
W _T	7.5	7.5	8.5	9	10
CB	15	17	19	21	24
CC (Nominal×Pitch)	M10×1.25	M12×1.25	M14×1.5	M16×1.5	M20×1.5

Model No. Indication (Speed Control Valve for High Pressure)

BZT 0 10 1 - A

1 2 3



1 G Thread Size

- 10 : Thread Part G1/8A Thread
- 20 : Thread Part G1/4A Thread

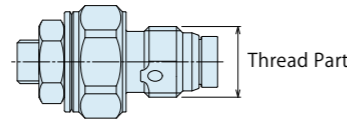

2 Design No.

- 1 : Revision Number

3 Control Method

- A : Meter-in

※ Meter-out option is not available for BZT.

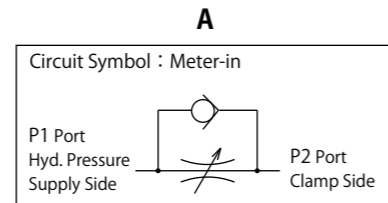

Specifications

Model No.	BZT0101-A	BZT0201-A
Max. Operating Pressure	MPa	35
Min. Operating Pressure	MPa	10
Control Method	Meter-in	
G Thread Size	G1/8A	G1/4A
Cracking Pressure	MPa	0.04
Max. Passage Area	mm ²	2.6
Usable Fluid	General Hydraulic Oil Equivalent to ISO-VG-32	
Operating Temperature	°C 0 ~ 70	
Tightening Torque for Main Body	N·m	10
Weight	g	12

- Notes:
1. It must be mounted with recommended torque. Because of the structure of the metal seal, if mounting torque is insufficient, the flow control valve may not be able to adjust the flow rate.
 2. Do not attach a used BZT to other clamps. Flow control will not be made because the bottom depth difference of G thread makes metal seal insufficient.

Applicable Products

Model	TTA (Double Action) Linear Cylinder
BZT0101-A	TTA0360-C□-□
	TTA0400-C□-□
	TTA0480-C□-□
	TTA0550-C□-□
BZT0201-A	TTA0650-C□-□

Note: 1. Control method of TTA should be meter-in circuit for both lock side and release side. Meter-out circuit causes abnormal high pressure leading to oil leakage and damage.

External Dimensions

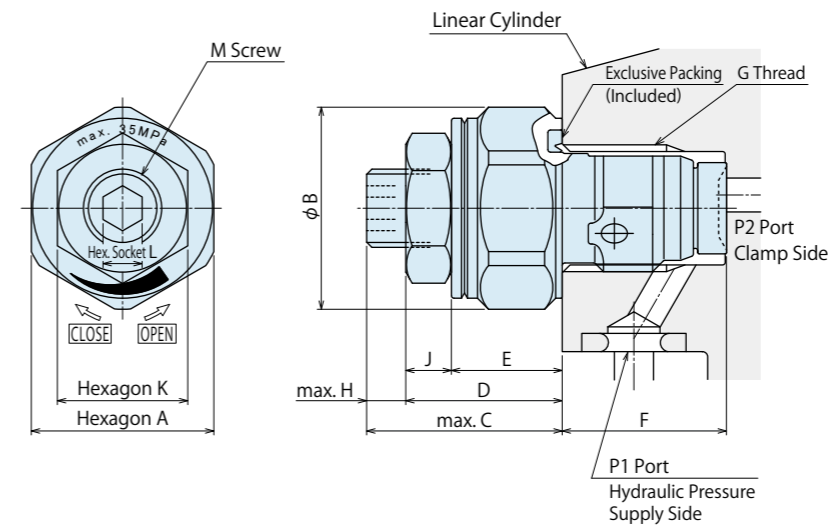

Machining Dimensions of Mounting Area

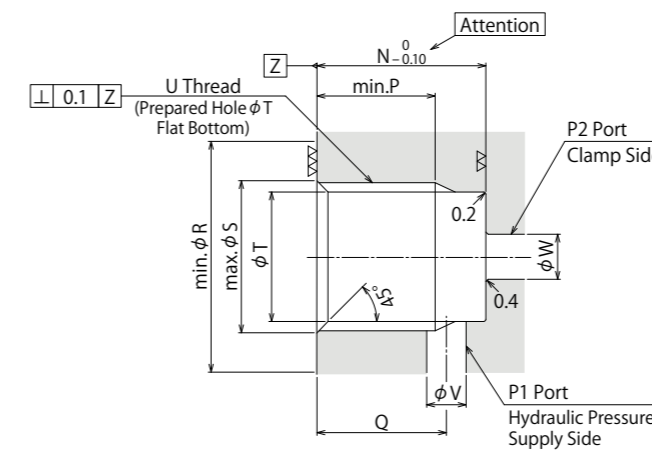

Model No.	BZT0101-A	BZT0201-A
A	14	18
B	15.5	20
C	15	16
D	12	13
E	8.5	9.5
F	(12.6)	(16.1)
G	G1/8	G1/4
H	3	3
J	3.5	3.5
K	10	10
L	3	3
M (Nominal×Pitch)	M6×0.75	M6×0.75
N	12.5	16
P	8.5	11
Q	9.5	12
R	16	20.5
S	10	13.5
T	8.7	11.5
U	G1/8	G1/4
V	2.5 ~ 3.5	3.5 ~ 4.5
W	2.5 ~ 5	3.5 ~ 7

Notes:

1. Since the ▽▽ area is sealing part, be careful not to damage it.
2. Since the ▽▽ area is the metal sealing part of BZL, be careful not to damage it. (Especially when deburring)
3. No cutting chips or burr should be at the tolerance part of machining hole.
4. As shown in the drawing, P1 port is used as the hydraulic supply side and P2 port as the clamp side.

Notes

1. Please read "Notes on Hydraulic Cylinder Speed Control Unit" for proper hydraulic circuit design. Improper circuit design may lead to malfunctions and damages. (Refer to P.17)
2. It is dangerous to release the air under high pressure. It must be done under lower pressure. (For reference : the minimum operating range of the product within the circuit.)
3. When the cylinder capacity is small, the speed of flow may not be controlled properly. (Recommended Cylinder Capacity : 3cm³ or more)

G-Thread Fitting



The products on this section are made by Ihara Science Corp.

※ Appearance and specifications may be different due to the specification change made by the manufacturer.

Installataion

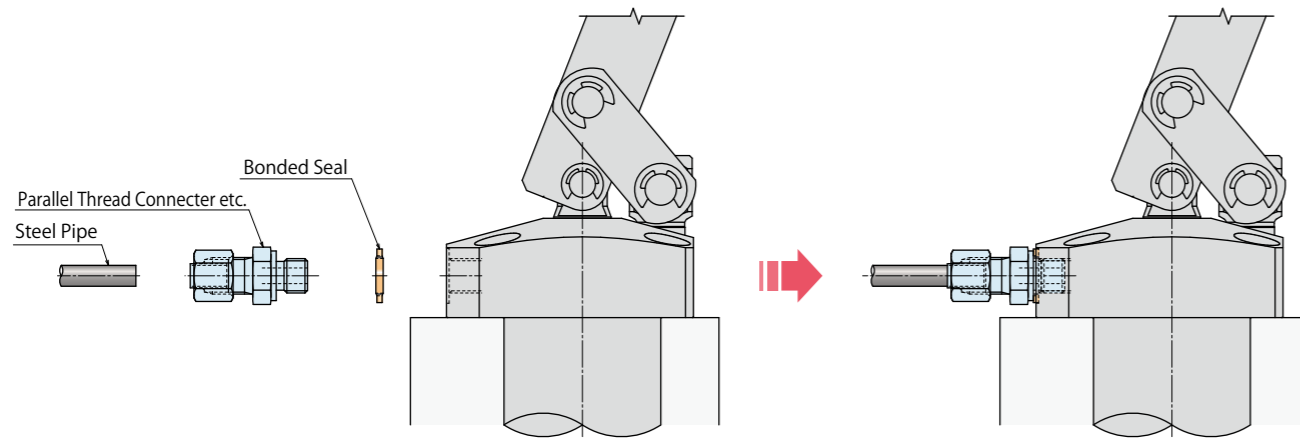

Before Mounting

After Mounted

Note :

※ Please put bonded seal between clamp and parallel connector etc (fitting) for sealing G thread with our clamp. It cannot be used in models with O-rings seal type.

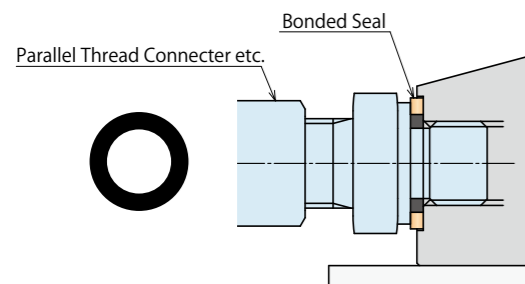

Please put bonded seal between clamp and parallel connector etc (fitting).

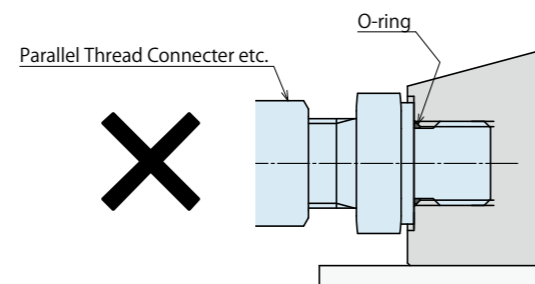

It cannot be used in models with O-rings seal type.

Bonded Seal

Model No. Indication

9UKP0C000 1

G Thread Size
(Refer to the following table.)

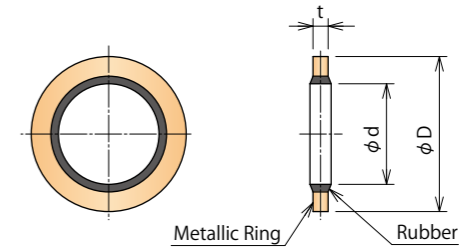

	(mm)		
Model No.	9UKP0C0001	9UKP0C0002	9UKP0C0003
Applicable Thread	G1/8	G1/4	G3/8
d	9.9	13.3	16.8
D	17	20.5	24
t	2	2	2

Note : 1. Rubber material is NBR, metallic ring is SPCC of JWG3141 (Cold pressure deferred steel sheet) used as standard specification. (Operating temperature -20°~120°C)

Parallel Thread Connector

Model No. Indication

9UKC0 06 0 1 E

G Thread Size
(Refer to the following table.)
Applicable Pipe External Diameter
(Refer to the following table.)

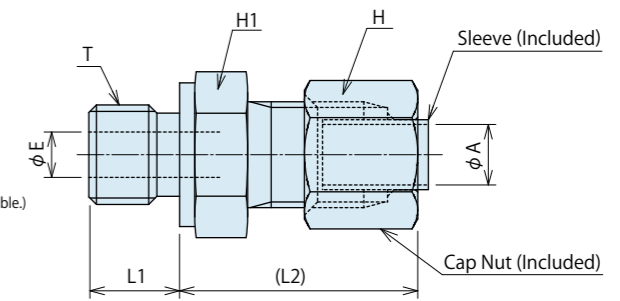

	(mm)				
Model No.	9UKC00601E	9UKC00801E	9UKC00602E	9UKC00802E	9UKC01203E
Applicable Pipe External Diameter φA	6	8	6	8	12
Applicable Thread T	G1/8	G1/8	G1/4	G1/4	G3/8
E	4	4	4	6	8
Hexagon Opposite Side H1	14	17	19	19	22
Hexagon Opposite Side H	14	17	14	17	22
L1	8	8	12	12	12
Tighten by Hand (L2)	(30.5)	(30.5)	(31.5)	(31.5)	(33.5)
Weight (kg)	0.030	0.042	0.048	0.053	0.087

Note : 1. Bonded seal is not included to this product. Please prepare separately.

Parallel Thread Adapter

Model No. Indication

9UKHB 06 0 1 E

G Thread Size
(Refer to the following table.)
Applicable Pipe External Diameter
(Refer to the following table.)

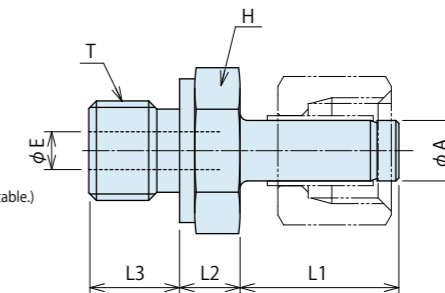

	(mm)		
Model No.	9UKHB0601E	9UKHB0802E	9UKHB1203E
Applicable Pipe External Diameter φA	6	8	12
Applicable Thread T	G1/8	G1/4	G3/8
E	3	5	8
Hexagon Opposite Side H	14	19	22
L1	21	21	22.5
L2	7	8	9.5
L3	8	12	12
Weight (kg)	0.016	0.033	0.051

Note : 1. Bonded seal is not included to this product. Please prepare separately.

● Stud Elbow Fitting

Model No. Indication

9UKMB 06 0 1 E

G Thread Size
(Refer to the following table.)
Applicable Pipe External Diameter
(Refer to the following table.)

Model No.	9UKMB0601E	9UKMB0802E	9UKMB1203E
Applicable Pipe External Diam. ϕA	6	8	12
Applicable Thread T	G1/8	G1/4	G3/8
E1	4	6	10
E2	4	7	9
Hexagon Opposite Side H1	17	22	27
Hexagon Opposite Side H	14	17	22
L1	8	12	12
L2	13	16	19
L3	14	17	22
Tighten by Hand (L4)	(33.5)	(35.5)	(40.5)
Weight (kg)	0.078	0.127	0.232

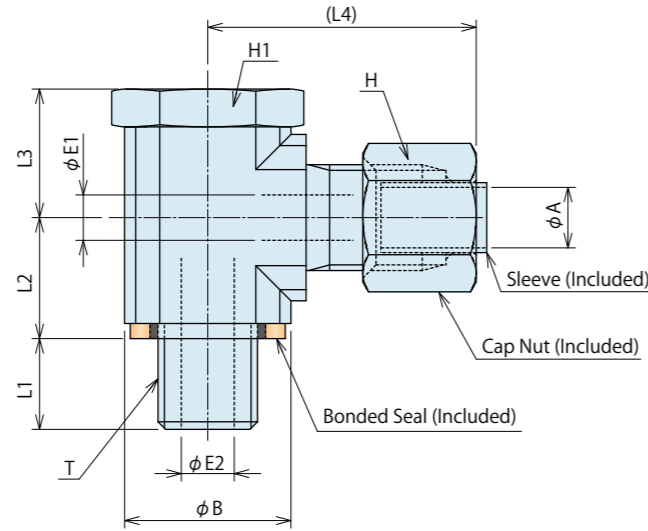

Note : 1. Do not use it as an alternative one of swivel fitting to make a turn.

● Union Fitting (Tee-Union Fitting)

Model No. Indication

9UKTA 06 00E

Applicable Pipe External Diameter.
(Refer to the following table.)

Model No.	9UKTA0600E	9UKTA0800E	9UKTA1200E
Applicable Pipe External Diam. ϕA	6	8	12
E	4	6	10
Width across Flats h	14	17	19
Hexagon Opposite Side H	14	17	22
Tighten by Hand (L)	(30.5)	(33.5)	(35.5)
Weight (kg)	0.069	0.122	0.172

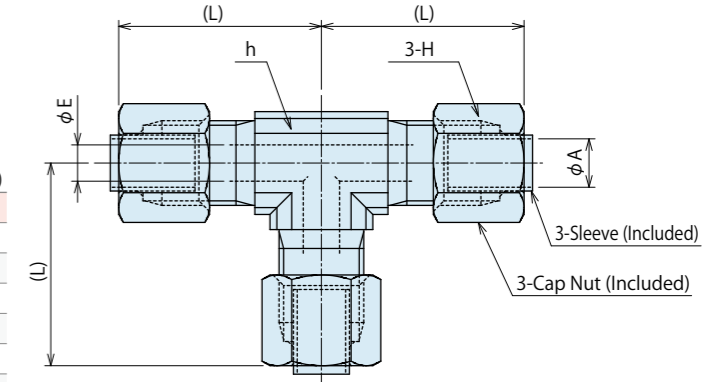

● Union Fitting

Model No. Indication

9UKUA 06 00E

Applicable Pipe External Diameter
(Refer to the following table.)

Model No.	9UKUA0600E	9UKUA0800E	9UKUA1200E
Pipe External Diam. ϕA	6	8	12
E	4	6	10
Hex. Opposite Side H1	14	17	19
Hex. Opposite Side H	14	17	22
Tighten by Hand (L)	(51)	(52)	(54)
Weight (kg)	0.042	0.059	0.093

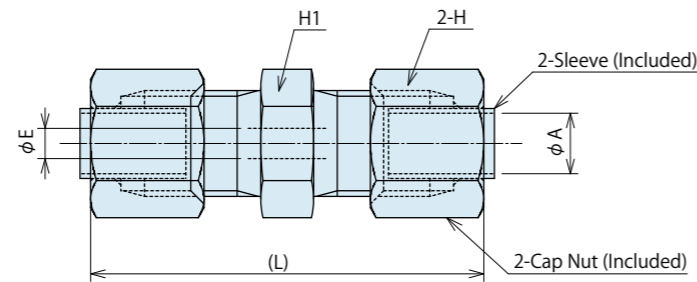

● Cap Nut

Model No. Indication

9UKKN 06 00E

Applicable Pipe External Diameter
(Refer to the following table.)

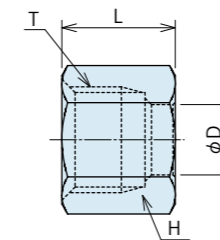

Model No.	9UKKN0600E	9UKKN0800E	9UKKN1200E
Applicable Pipe External Diam. ϕA	6	8	12
D	7.3	9.3	13.3
T	M12×1.5	M14×1.5	M18×1.5
Hexagon Opposite Side H	14	17	22
L	15	15	16
Weight (kg)	0.010	0.015	0.026

● Sleeve

Model No. Indication

9UKK0 06 00E

Applicable Pipe External Diameter
(Refer to the following table.)

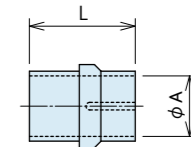

Model No.	9UKK00600E	9UKK00800E	9UKK01200E
Applicable Pipe External Diam. ϕA	6	8	12
L	14	14	15
Weight (kg)	0.002	0.003	0.004

● Union Fitting (Elbow)

Model No. Indication

9UKLA 06 00E

Applicable Pipe External Diameter
(Refer to the following table.)

Model No.	9UKLA0600E	9UKLA0800E	9UKLA1200E
Pipe External Diam. ϕA	6	8	12
E	4	6	10
Width across Flats h	14	17	19
Hex. Opposite Side H	14	17	22
Tighten by Hand (L)	(30.5)	(33.5)	(35.5)
Weight (kg)	0.048	0.081	0.116

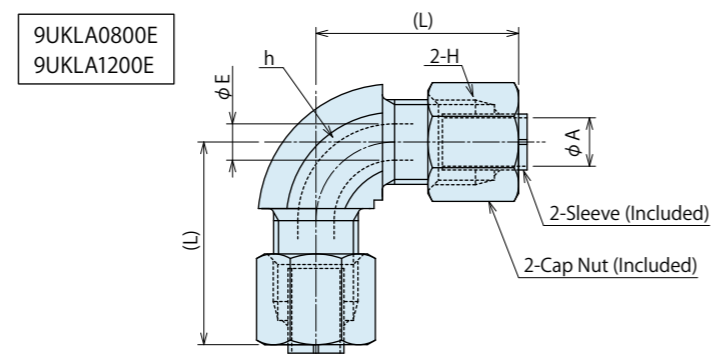
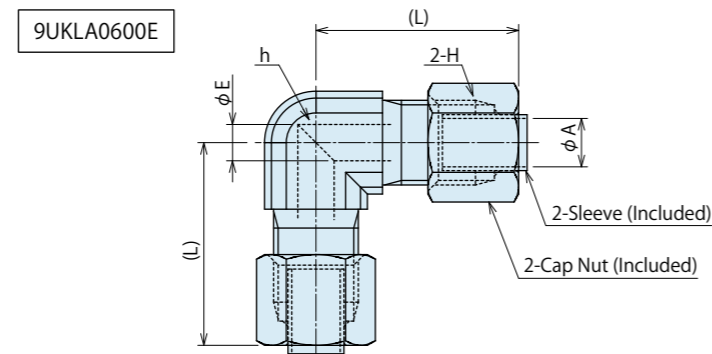

Cautions

● Notes for Design

- 1) Check Specifications
 - Please use each product according to the specifications.
- 2) Notes for Circuit Design
 - Please read "Notes on Hydraulic Cylinder Speed Control Unit" for proper hydraulic circuit design. Improper circuit design may lead to malfunctions and damages. (Refer to P.17)
 - Ensure there is no possibility of supplying hydraulic pressure to the push side and the pull side simultaneously.
- 3) Notes for Pipe Design
 - It is recommended to select as large diameter pipes as possible. The back pressure is proportional to the pipe size, so if the pipes are small the release and lock times will be longer.
- 4) Protect the exposed area of the piston rod when using on a welding fixture.
 - If spatter attaches to the sliding surface it could lead to malfunction and fluid leakage.
- 5) The Load Direction Given to the Piston Rod
 - Make sure no force is applied to the piston rod except from the axial direction. Usage like the one shown in the figure below will apply a large bending stress to the piston rod and must be avoided.

In case a load is applied except from the axial direction

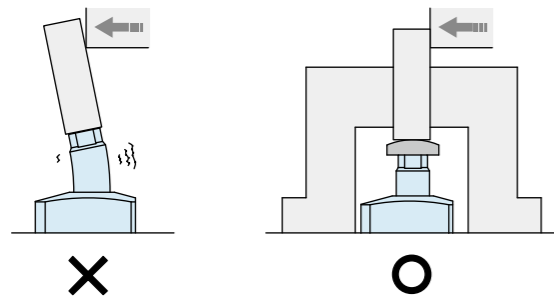

When clamping workpieces of different heights

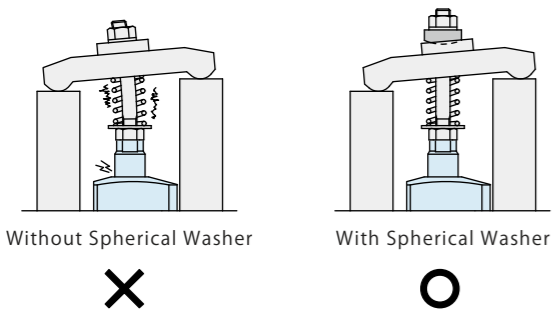

A Combination with Link Mechanism

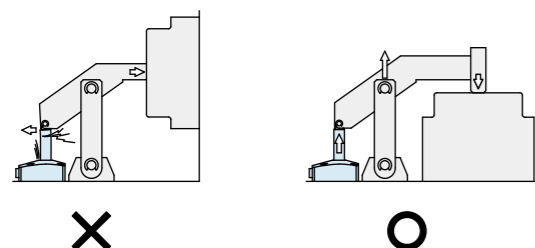

- 6) When Clamping on a Sloped Surface of a Workpiece
 - When clamping an inclined surface, install an attachment like shown in the following, and make sure no force is applied to the piston rod except from the axial direction. A workpiece may move and a piston rod may slip when a cylinder is used on an inclined surface. (When the workpiece is a casting, it is recommended that a spiked attachment be used for a cylinder on draft angle.)

When clamping an inclined surface

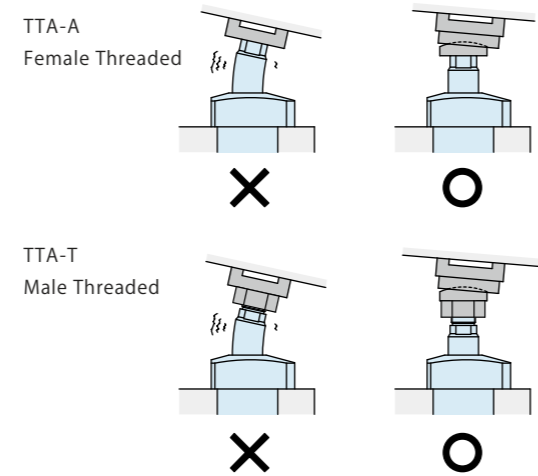

● Installation Notes

- 1) Check the Usable Fluid
 - Please use the appropriate fluid by referring to the Hydraulic Fluid List on the next page (P.16).
- 2) Procedure before Piping
 - The pipeline, piping connector and fixture circuits should be cleaned by thorough flushing.
 - The dust and cutting chips in the circuit may lead to fluid leakage and malfunction.
 - There is no filter provided with Kosmek's product except for a part of valves which prevents foreign materials and contaminants from getting into the circuit.
- 3) Applying Sealing Tape
 - Wrap with tape 1 to 2 times following the screw direction.
 - Pieces of the sealing tape can lead to oil leakage and malfunction.
 - Please implement piping construction in a clear environment to prevent anything getting in products.
- 4) Installation of the Cylinder
 - When mounting the cylinder, use four hexagonal socket bolts (with tensile strength of 12.9) and tighten them with the torque shown in the table below. Tightening with greater torque than recommended can dent the seating surface or break the bolt.

Model No.	Mounting Bolt Size	Tightening Torque (N·m)
TTA0360	M4×0.7	3.2
TTA0400	M5×0.8	6.3
TTA0480	M5×0.8	6.3
TTA0550	M6×1	10
TTA0650	M6×1	10

- 5) Installation / Removal of Attachment
 - When installing or removing an attachment, always use a wrench on the piston rod to keep it from turning, and tighten it with the torque shown below.

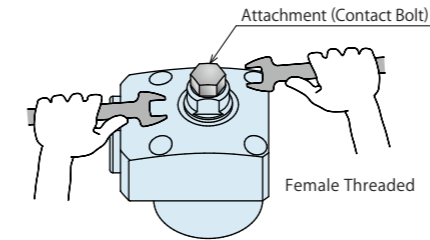

TTA□-CA : Female Threaded

Model No.	Thread Size	Tightening Torque (N·m)
TTA0360-CA	M8×1.25	16
TTA0400-CA	M8×1.25	16
TTA0480-CA	M10×1.5	40
TTA0550-CA	M10×1.5	40
TTA0650-CA	M12×1.75	80

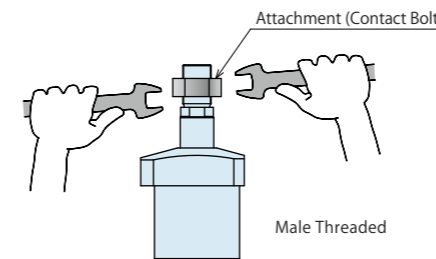

TTA□-CT : Male Threaded

Model No.	Thread Size	Tightening Torque (N·m)
TTA0360-CT	M10×1.25	40
TTA0400-CT	M12×1.25	63
TTA0480-CT	M14×1.5	80
TTA0550-CT	M16×1.5	100
TTA0650-CT	M20×1.5	200

- 6) Speed Adjustment
 - Adjust the operating speed of the push side and the pull side to be less than 100mm/sec. If the cylinder operates too fast the parts will be worn out leading to premature damage and ultimately complete equipment failure.
 - Please make sure to release air from the circuit before adjusting speed. It will be difficult to adjust the speed accurately with air mixed in the circuit.
 - Turn the speed control valve gradually from the low-speed side (small flow) to the high-speed side (large flow) to adjust the speed.

- 7) Air Bleeding of the Hydraulic Circuit
 - If the hydraulic circuit has excessive air, the action time may become very long. If air enters the circuit after connecting the hydraulic port or under the condition of no air in the oil tank, please perform the following steps.

- ① Reduce hydraulic pressure to less than 2MPa.
- ② Loosen the cap nut of pipe fitting closest to the clamp by one full turn.
- ③ Shake the pipeline to loosen the outlet of pipe fitting. Hydraulic fluid mixed with air comes out.

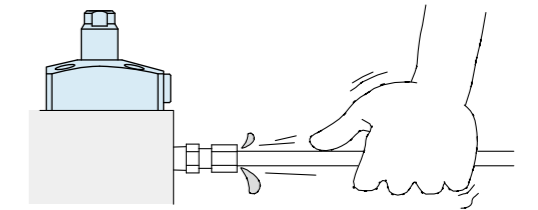

- ④ Tighten the cap nut after bleeding.
- ⑤ It is more effective to release air at the highest point inside the circuit or at the end of the circuit. (Set an air bleeding valve at the highest point inside the circuit.)

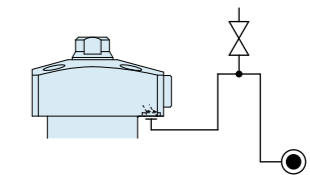

- 8) Checking Looseness and Retightening
 - At the beginning of the machine installation, the bolt and nut may be tightened lightly. Check the looseness and re-tighten as required.

● Hydraulic Fluid List

Maker	ISO Viscosity Grade ISO-VG-32	
	Anti-Wear Hydraulic Oil	Multi-Purpose Hydraulic Oil
Showa Shell Sekiyu	Tellus S2 M 32	Morlina S2 B 32
Idemitsu Kosan	Daphne Hydraulic Fluid 32	Daphne Super Multi Oil 32
JX Nippon Oil & Energy	Super Hyrando 32	Super Mulpus DX 32
Cosmo Oil	Cosmo Hydro AW32	Cosmo New Mighty Super 32
ExxonMobil	Mobil DTE 24	Mobil DTE 24 Light
Matsumura Oil	Hydol AW-32	
Castrol	Hyspin AWS 32	

Note : Please contact manufacturers when customers require products in the list above.

Cautions

● Notes on Hydraulic Cylinder Speed Control Unit



Please pay attention to the following note.
Design the hydraulic circuit for controlling the action speed of hydraulic cylinder. Improper circuit design may lead to malfunctions and damages.
Please review the circuit design in advance.

- Flow Control Circuit for Double-Acting Linear Cylinder (TTA)
Control method of TTA should be meter-in circuit for both lock side and release side. Meter-out circuit causes abnormal high pressure leading to oil leakage and damage.

【Meter-in Circuit】

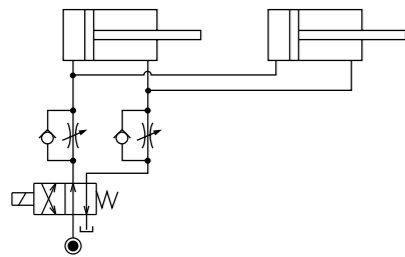

● Notes on Handling

- 1) It should be operated by qualified personnel.
- The hydraulic machine and air compressor should be operated and maintained by qualified personnel.
- 2) Do not operate or remove the product unless the safety protocols are ensured.
 - ① The machine and equipment can only be inspected or prepared when it is confirmed that the safety devices are in place.
 - ② Before the product is removed, make sure that the above-mentioned safety devices are in place. Shut off the pressure and power source, and make sure no pressure exists in the air and hydraulic circuits.
 - ③ After stopping the product, do not remove until the temperature drops.
 - ④ Make sure there is no abnormality in the bolts and respective parts before restarting the machine or equipment.
- 3) Do not touch a cylinder while it is working. Otherwise, your hands may be injured.

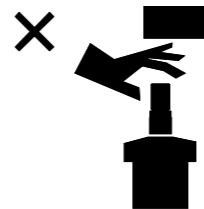

- 4) Do not disassemble or modify.
 - If the equipment is taken apart or modified, the warranty will be voided even within the warranty period.

● Maintenance and Inspection

- 1) Removal of the Machine and Shut-off of Pressure Source
 - Before the machine is removed, make sure that safety devices and preventive devices are in place. Shut off the pressure and power source, and make sure no pressure exists in the air and hydraulic circuits.
 - Make sure there is no abnormality in the bolts and respective parts before restarting.
- 2) Regularly clean the area around the piston rod.
 - If it is used when the surface is contaminated with dirt, it may lead to packing seal damage, malfunctioning and fluid leakage.

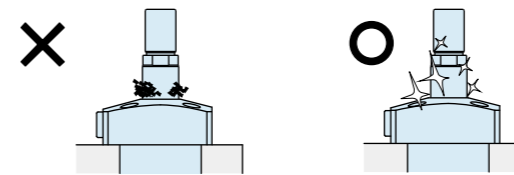

- 3) If disconnecting by couplers, air bleeding should be carried out on a regular basis to avoid air mixed in the circuit.
- 4) Regularly tighten piping, mounting bolt and others to ensure proper use.
- 5) Make sure the hydraulic fluid has not deteriorated.
- 6) Make sure there is a smooth action without an irregular noise.
 - Especially when it is restarted after left unused for a long period, make sure it can be operated correctly.
- 7) The products should be stored in the cool and dark place without direct sunshine or moisture.
- 8) Please contact us for overhaul and repair.

● Warranty

- 1) Warranty Period
 - The product warranty period is 18 months from shipment from our factory or 12 months from initial use, whichever is earlier.
- 2) Warranty Scope
 - If the product is damaged or malfunctions during the warranty period due to faulty design, materials or workmanship, we will replace or repair the defective part at our expense. Defects or failures caused by the following are not covered.
 - ① If the stipulated maintenance and inspection are not carried out.
 - ② If the product is used while it is not suitable for use based on the operator's judgment, resulting in defect.
 - ③ If it is used or operated in an inappropriate way by the operator. (Including damage caused by the misconduct of the third party.)
 - ④ If the defect is caused by reasons other than our responsibility.
 - ⑤ If repair or modifications are carried out by anyone other than Kosmek, or without our approval and confirmation, it will void warranty.
 - ⑥ Other caused by natural disasters or calamities not attributable to our company.
 - ⑦ Parts or replacement expenses due to parts consumption and deterioration. (Such as rubber, plastic, seal material and some electric components.)

Damages excluding from direct result of a product defect shall be excluded from the warranty.



WAHLTEC GmbH
Ravensburger Str. 14
88361 Altshausen
T: +49 (7584) 9238883
F: +49 (7584) 9238887

www.wahltec.de