



All-In-One High Precision Locating and Powerful Clamping!

# Centering Pallet Clamp



• **3 μm Repeated Locating Accuracy**

Just one datum clamp enables both X and Y locating and clamping. The clamp includes seating surfaces, built-in seat check valves and air blow capabilities. [Locating Repeatability : 3 μm]

• **Clamping Function**

Spring clamp and hydraulic release.

• **Self Absorbing Taper Sleeve**

Marginal error absorbed by the taper sleeve. The clearance between the clamp, taper sleeve and female block is eliminated. This enables the repeated locating accuracy and stabilized clamping force.

• **Application Examples**

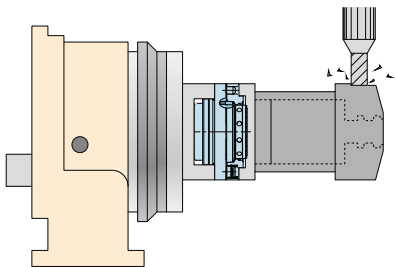

For Index Tables

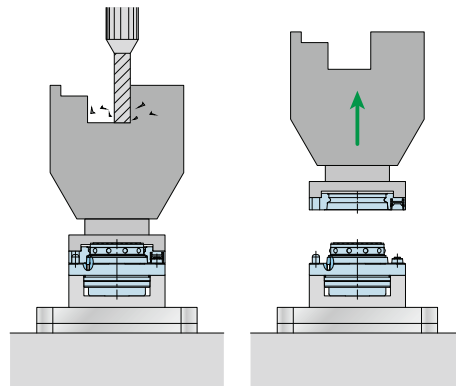

For Machining Centers

EXAMPLE SPECIFICATION :  
Please contact us for dimensions not listed in this leaflet.

• **Specifications**

Clamping Force	kN	10	16	25
Locating Repeatability	mm	0.003		
Full Stroke	mm	3.4	4	4.7
Lifting Up Stroke	mm	1.0		
Allowable Offset when fixture loading	mm	1.5		
	At 7.0MPa	11.0	17.7	27.7
Lifting Up Force	kN	5.4	8.8	13.5
	At 3.5MPa	1.2	2.2	2.9
Max. Loading Weight	kg	1000	1600	2500
Cylinder Capacity	cm <sup>3</sup>	9.6	17.7	33.3
Releasing Hyd. Pressure	MPa	7.0		
	Max. Operating Pressure	3.5		
	Min. Operating Pressure	10.5		
Operating Air Pressure (Air Blow Use)	MPa	0.4 ~ 0.5		
	Withstanding Pressure	0 ~ 70		
Operating Temperature	°C	0 ~ 70		
Usable Fluid		General Hydraulic Oil Equivalent to ISO-VG-32		

• **External Dimensions**

1. This drawing shows the released state of VY.

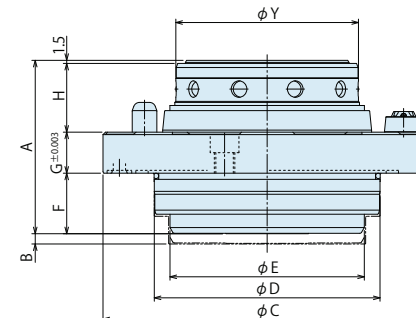
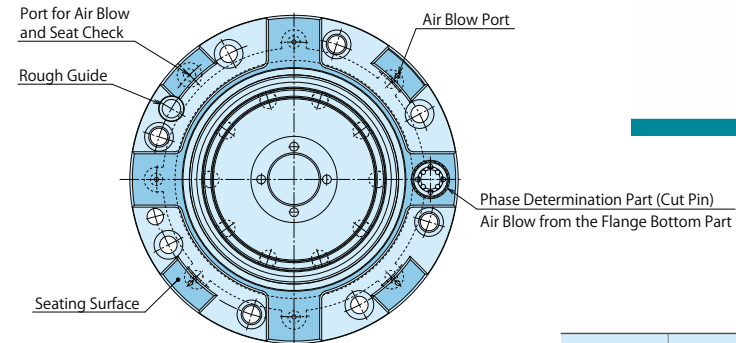

WAHLTEC GmbH  
T: +49 (7584) 9238883  
F: +49 (7584) 9238887  
kosmek@wahltec.de  
www.wahltec.de

Clamping Force	10kN	16kN	25kN
A	56.5	70	84.5
B	4	4.5	5
C	100	125	160
D	74	89	110
E	60	75	95
F	21	26	29.5
G	12	15	20
H	22	27.5	33.5
Y	59	72	89

Please contact us for dimension of the block.

• IF THERE IS ANY UNCLEAR INFORMATION IN THIS LEAFLET, PLEASE CONTACT US.  
• SPECIFICATIONS IN THIS LEAFLET ARE SUBJECT TO CHANGE WITHOUT NOTICE.